

Product Name: **All New Boost Tee Manual Boost Controller**
Product Description: Manual Boost Controller
Product Number: TS-0101-110X



ABOUT THIS PRODUCT

Thank you for purchasing your new Turbosmart Boost Tee. This new model now has some great new features. These include:

- The option of either a slow boost ramp rate for sensitive setups or fast depending on Boost Tee configuration. This is achieved with either the restricted nipple as well as ball and spring.
- A wider boost adjustment range for wastegates with low spring base pressures.
- A new mounting bracket to make it easier to mount.

IMPORTANT NOTES ON YOUR BOOST CONTROLLER

- Use only silicone hose that is the correct size and pressure rating for your application when fitting your boost controller – other hoses will be affected by heat and will eventually crack or split which could cause excessive boost pressure and engine damage
- Ensure that all plumbing is secured with clamps or cable ties.
- Your boost controller should be mounted at least 100mm from any heat source
- A Turbosmart Fuel Cut Defender may need to be used in conjunction with your boost controller – refer to www.turbosmart.com.au
- **The boost dial has a left handed thread, be sure not to over tighten as this will damage the boost controller.**
- **Please note that the one turn (click) of the boost controller dial does NOT correspond to 1 PSI change in boost pressure.**

RECOMMENDATIONS

- Turbosmart recommends that the Air Fuel ratio is checked once boost pressure is set
- Turbosmart recommends that boost pressure is set using a Dynamometer and not on the street
- Turbosmart recommends that an accurate boost gauge be permanently fitted to the vehicle
- Turbosmart recommends that your boost controller is fitted and adjusted by an appropriately qualified technician

HOW TO INSTALL YOUR BOOST CONTROLLER

TOOLS REQUIRED

General mechanic tools

Internal Wastegate Setup

- Allow the engine to cool down before installing your boost controller
- Locate the pressure source port and the wastegate actuator port on the turbocharger assembly (refer drawing 1)
- Remove the factory boost control solenoid if fitted from the boost pressure supply port while leaving the solenoid connected to the ECU
- Install your boost controller in the wastegate pressure line with the wastegate arrow pointing towards the wastegate actuator
- If your wastegate actuator has additional ports, these will need to be blocked
- Secure all silicone hose ends with hose clamps
- Mount your boost controller bracket onto the vehicle, then attach the boost controller onto the bracket with the supplied screws
- Make sure the boost dial is turned completely anti-clockwise before adjusting.

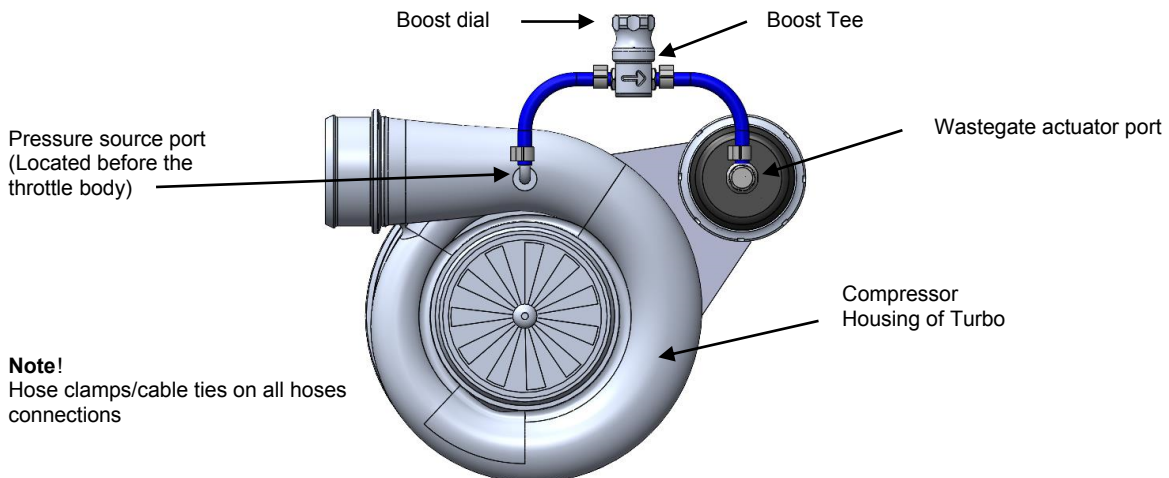

HOW TO INSTALL YOUR BOOST CONTROLLER cont.

External Wastegate Setup

- Allow the engine to cool down before installing your boost controller
- Locate the **bottom port** on the external wastegate and the pressure source port (refer Drawing 2)
- Install the Boost Tee in the wastegate pressure line with the wastegate arrow pointing towards the **bottom port** on the wastegate
- Secure all silicone hose ends with hose clamps
- Mount your boost controller bracket onto the vehicle, then attach the boost controller onto the bracket with the supplied screws
- Make sure the boost dial is turned completely anti-clockwise before adjusting.

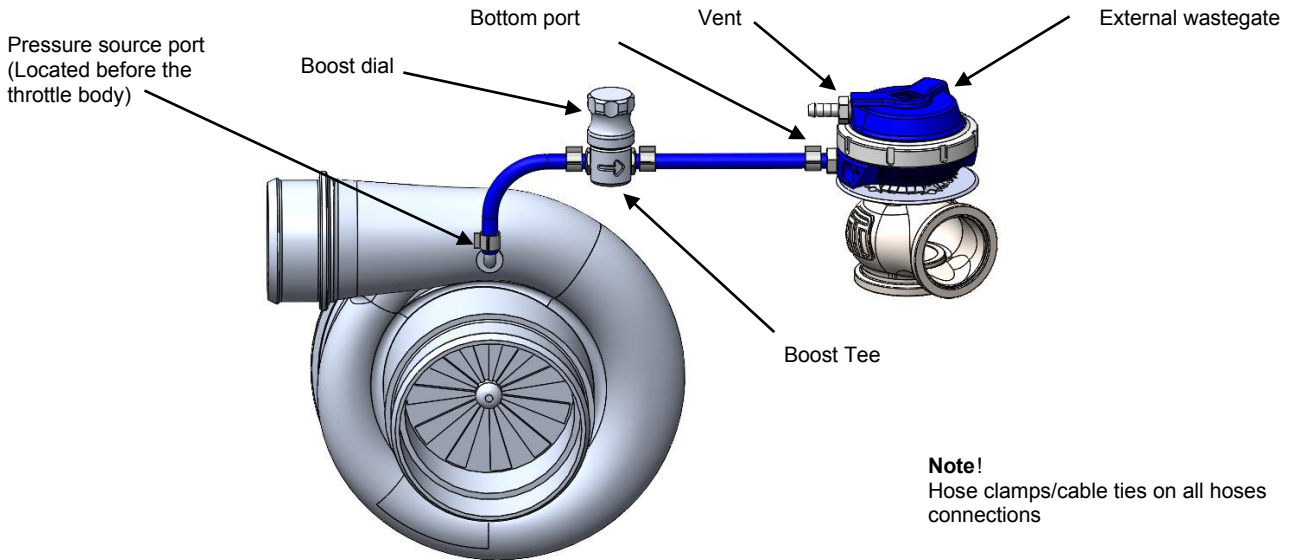

Parallel Twin Turbo Setup

- Allow the engine to cool down before installing your boost controller
- Locate the wastegate actuator ports on both turbochargers and a pressure source port (refer Drawing 3)
- Remove the factory boost control solenoid if fitted from the boost pressure supply line
- Install your boost controller in the wastegate pressure line with the wastegate arrow pointing towards the wastegate actuators. • Be sure to keep the hoses joining the wastegate actuators at equal lengths
- Secure all silicone hose ends with hose clamps
- Mount your boost controller bracket onto the vehicle, then attach the boost controller onto the bracket with the supplied screws
- Make sure the boost dial is turned completely anti-clockwise before adjusting.

*Note for sequential turbo systems: Sequential turbo setups can be complex and vary from car to car. Please contact your local Turbosmart dealer for more details

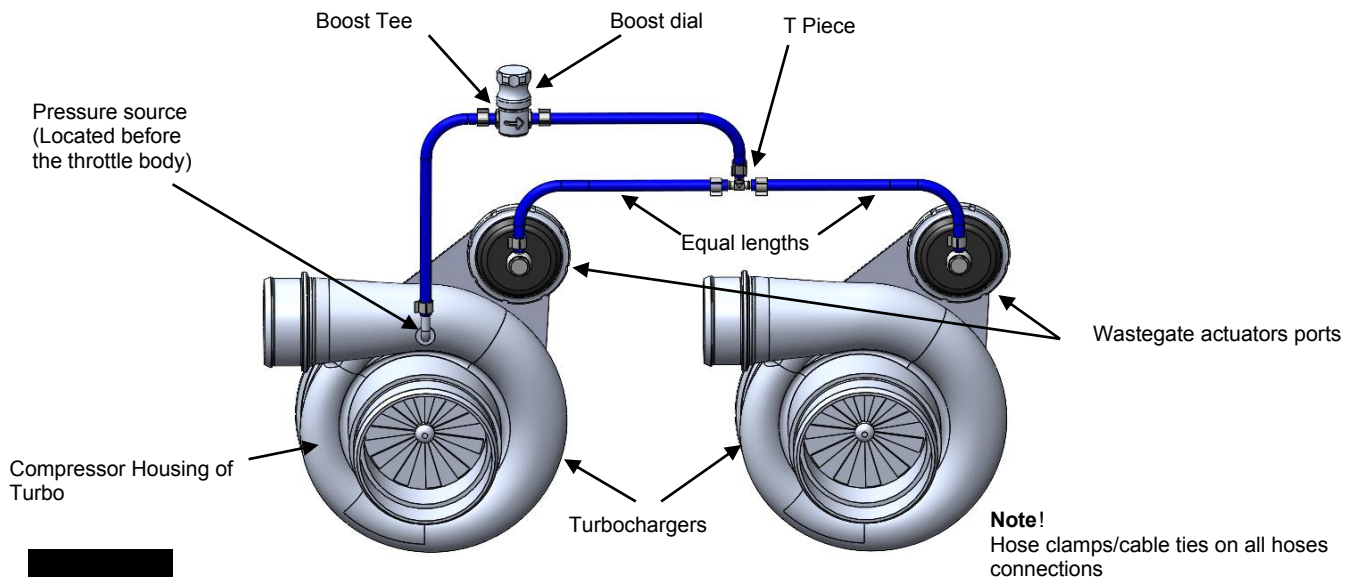

SETTING BOOST PRESSURE

Important notes on Boost Pressure Adjustment

- Adjustment to your boost controller is made by rotating the **Boost Dial**. Please note that the one turn (click) of the boost controller dial does NOT correspond to 1 PSI change in boost pressure.
- Rotate in a clockwise direction to increase boost and the reverse direction to decrease boost
- Before making any adjustment, the **Boost Dial** will need to be fully closed (anti-clockwise)

Step 1: Apply full load to the engine in a high gear (at least 3rd or 4th gear) at full throttle and note the boost pressure

Step 2: To increase boost rotate the **Boost Dial clockwise** (maximum of 1 complete revolution at a time)

Step 3: Apply full load to the engine and note the boost pressure

Step 4: Compare the actual boost pressure with the desired boost pressure. If the actual pressure is below the desired pressure, return to step 2. If the actual is above the desired boost then decrease by rotating the **Boost Dial anti-clockwise** and return to step 3.

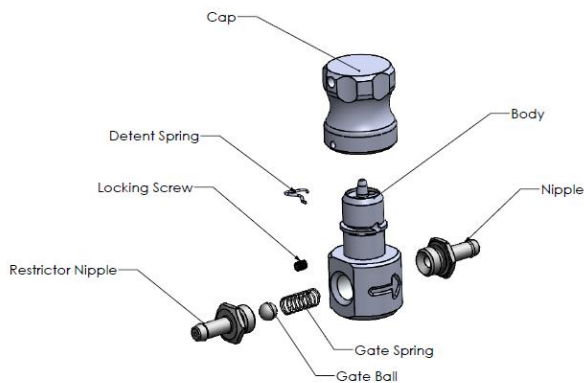

Boost Spiking

If boost spiking occurs and is undesirable for your application, the gate system can be removed to give you a less aggressive boost curve. This modification is only required in a minimal number of applications.

Bo

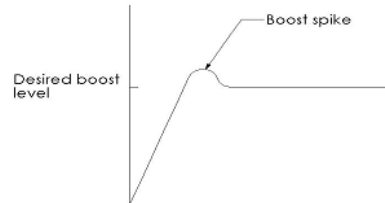

Ide

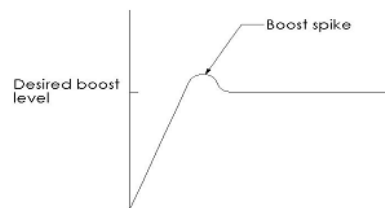

Important notes on Gate system removal

The gate system can be removed by the following steps. Perform this modification on a clean bench so that the ball and spring are not lost

- Allow the engine to cool down before removing the Boost Tee from your vehicle
- Identify the input nipple with the restrictor at the end. Loosen the input nipple and remove the ball and spring.
- Check that the internal air passages are clear and free from debris
- Re-install the boost controller by following the instructions for your setup
- You will need to re-adjust your boost settings after the removal of the gate.

TROUBLE SHOOTING

The following points should be checked if you find that your engine is developing excessive boost, the boost pressure is fluctuating, or the desired boost level cannot be achieved. Please note, the following checks will cure 99% of problems experienced when fitting a Turbosmart boost controller.

- Check that the boost controller is installed so that the arrow points toward the wastegate actuator
- Check the joining hoses for splits, cracks or loose connection and are the correct size for the application
- Check to see if the boost controller is blocked or contaminated with dirt or debris
- Ensure that there is nothing but the boost controller in the hose between the pressure source and the wastegate actuator, ie tee pieces for boost gauge or to factory boost solenoid.
- Pressure test the wastegate actuator for leakage, the diaphragm or housing may be cracked or split
- Check that the wastegate is operating correctly

