

Fitting Instructions #TRC4301IS

Volkswagen

Sway Bar Link Assembly



Contents

Description	Qty
M12 ball link LH thread	2
M12 ball link RH thread	1
M12 ball link RH thread with spacer	1
245mm (6060-T5 Aluminium alloy) Link	2
Instruction Sheet	1

Assembly Instruction

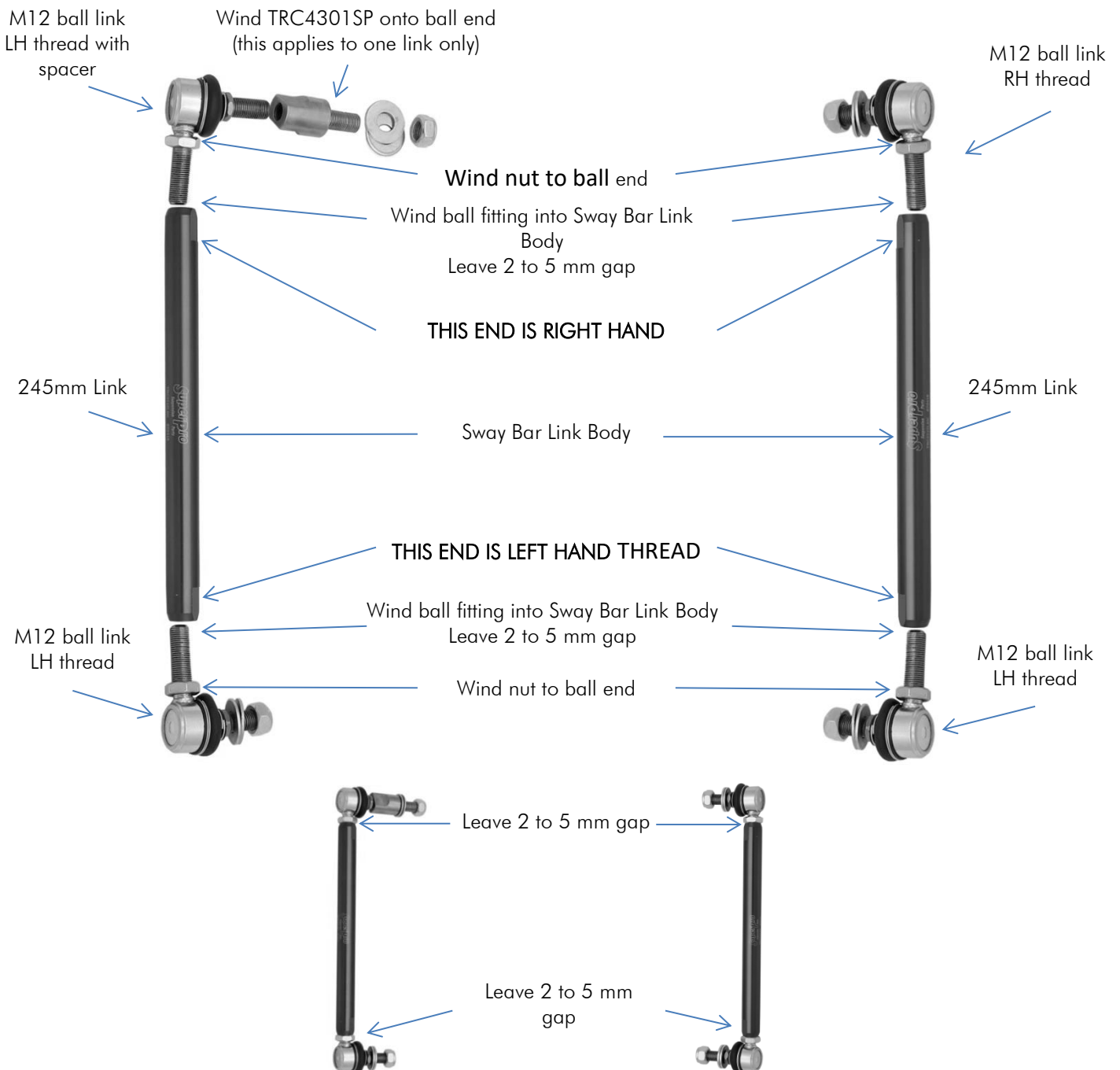

Installation Instruction

Directional references (left, right, front, rear) are always with reference to the driving direction.

Please note that the sway bar link assembly is not assembled.

For O.E. Struts:

- Remove [OE] sway bar link pin assembly;
- Measure the length of the [OE] link from the centre ball end to centre of ball end;
- Adjust the TRC4301 sway bar link to the same length as the [OE] assembly for [OE] sway bar and the soft position of an adjustable sway bar, ensuring a minimum of 15mm is maintained as per Figure 03. For other positions on adjustable sway bars, the link should be shortened accordingly;
- For the **Right Hand Side** of the vehicle the [OE] link pin is fitted to the Rear of the bracket as shown below. Refit TRC4301 link to the front of bracket to clear drive shaft as shown below.

Please Note: No Drive Shaft Clearance Extender is required for the right side.



- For the Left Hand Side the ball end is fitted to the front side of the bracket this must stay the same and fit TRC4301 with Drive Shaft Clearance Extender as shown below.
- After installation to vehicle, tension ball end nuts to 60Nm, after tensioning a full nut must be seen.
- Washers are supplied to be used where necessary.

Please Note: Over tightening ball end nuts will damage the thread.

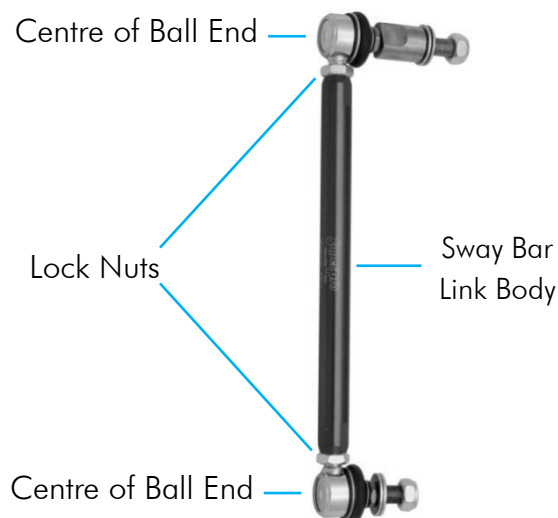
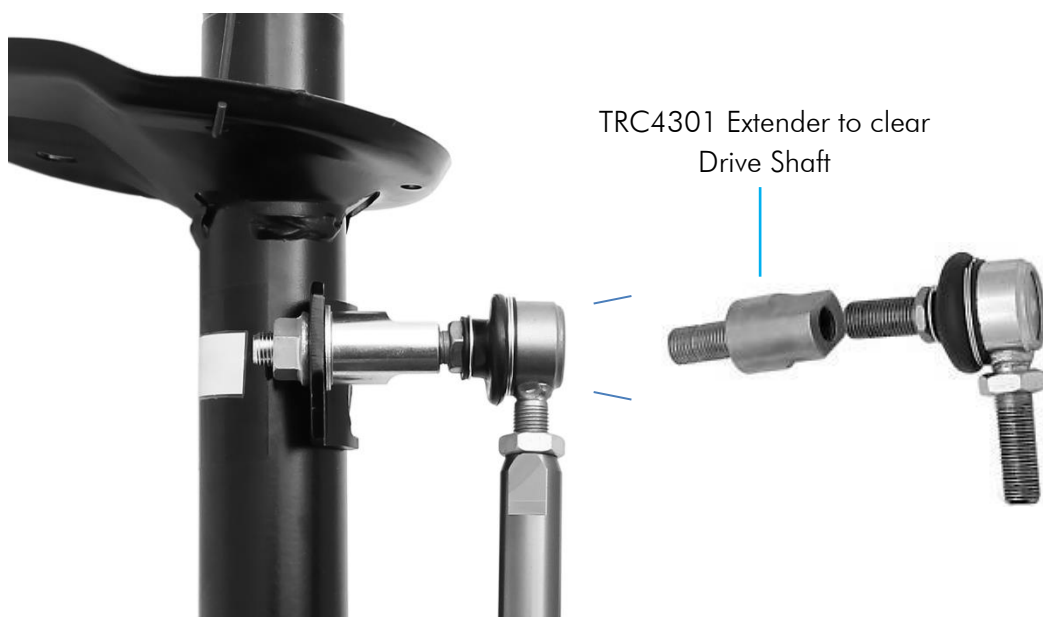

Figure 02 – Left Hand Side Link installation

For Aftermarket Coilovers:

- The above instructions apply to coil overs; however it may be necessary to shorten TRC4301 links to allow for a shorter body coil over.

Please Note: Left Hand Side is installed first.

- For the **Left Hand Side** a minimum distance of 15mm between the Sway Bar (Anti-Roll Bar, Figure 3 over page) and the Control Arm at full suspension droop needs to be maintained as shown below.
- For the **Right Hand Side** the link is adjusted to a length that allows link to be fitted without tension.

Please Note: Failure to adhere to this procedure may result in component failure.

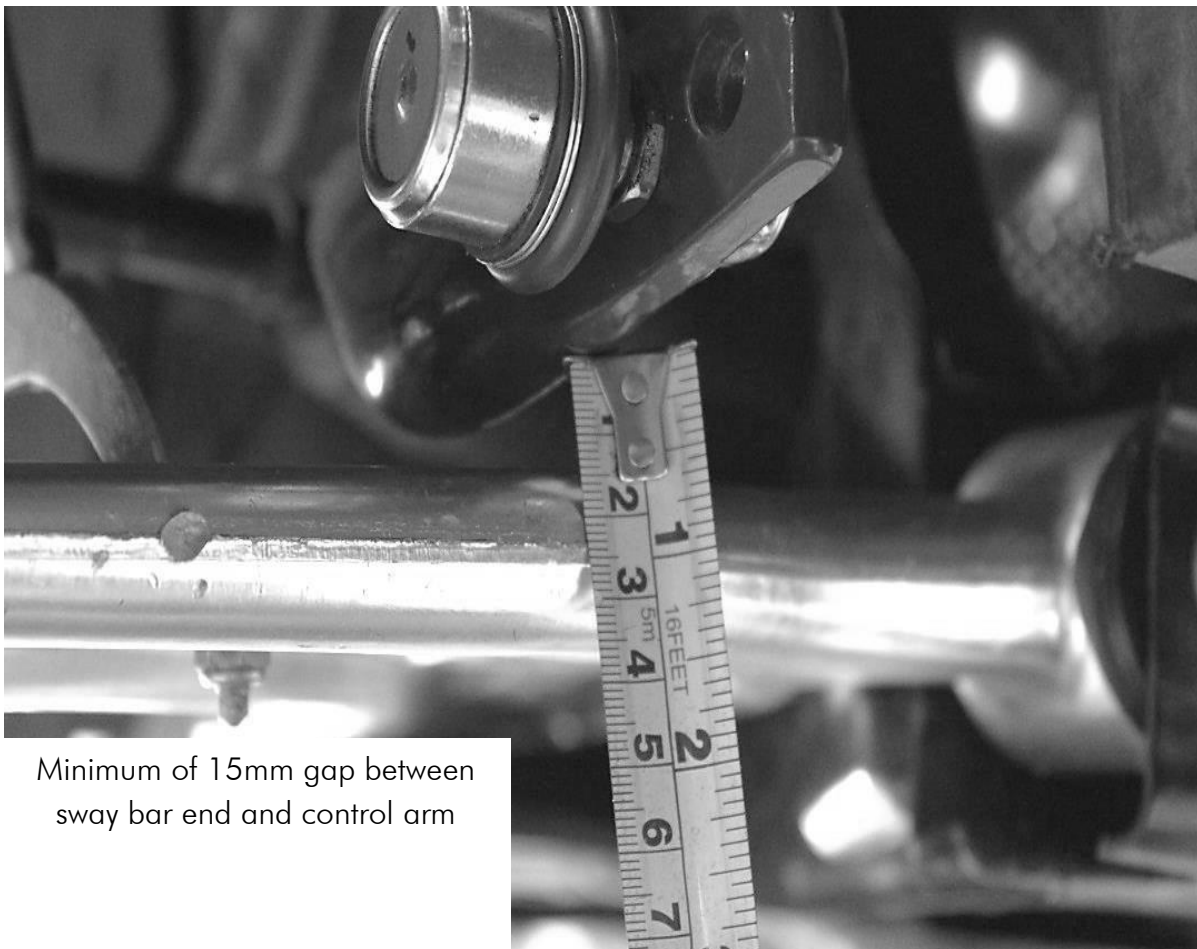

Figure 03 – Gap between link and control arm