



AVO Castor Adjustment Bushing Fitting Guide

PN# S1X03E1GV001T +0.50

PN# S1X03E1GV002T +0.00

Applied Models:

2005-09 Legacy GT, Spec B

2009+ Forester XT

2008+ Impreza WRX & STI



You are now the proud owner of a highly tested and proven AVOTurboworld Caster Adjustment Bushing (CAB) kit. This kit upgrades the bushing in the lower control arm. While you have made a wise choice in selecting this suspension part, below we have some suggestions and procedures for you to follow to ensure a successful installation.

Tools Required

- Metric Socket Set
- Metric wrench Set
- Mechanical Press

Kitting List

Note: Check this kit list before starting the install to make that you have all these parts.

1 x S1X03E1GV001T CAB Kit	1 x Grease packet	2 x 19x45mm washer

Before grabbing a bunch of spanners and attacking your car take a moment to

STOP AND THINK

Read these supplied installation instructions thoroughly from start to finish – do you understand all of the mechanical operations required? Are you sure that you can adequately complete all of the mechanical operations required?

Installation

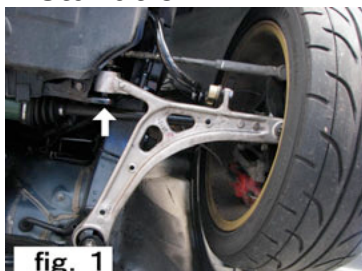

First you will need to remove the control arms from the vehicle. You will need to unbolt the front first. (Figure 1)

Illustration is of the control arm assembly from above.



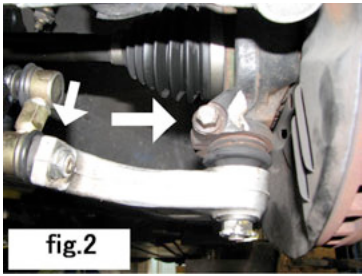

Unbolt the stabilizer bar end-link and the strut ball-joint at end of the control arm.

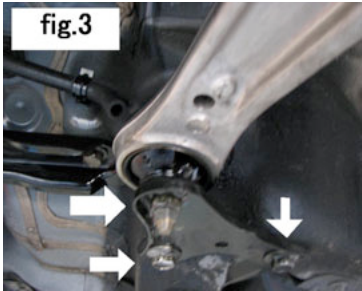

Unbolt the mounting brace from the vehicle first, and then unbolt the center nut from the Stud bolt.

When you remove the center nut from the lower arm, if the stud bolt comes out replace it with a new stud bolt. Refer to the Subaru manual for torque specs.



Remove the rubber bush assembly from the control arm with a hand press or mechanical press.

Press the AVO CAB bushing outer assembly into the control arm with a mechanical or hand press.

The CAB outer metal sleeve has a small raised lip at the top outer edge. This is to keep the CAB from being pushed out of the control arm in heavy use.

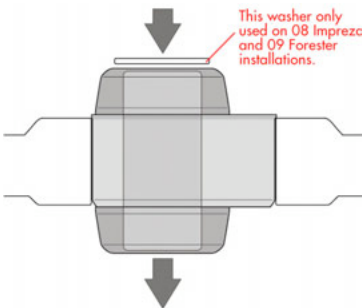
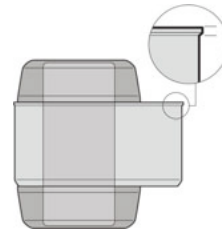

The CAB sleeved assembly must be pressed in from the top of the control arm assembly, with the lip at the top. This holds the assembly in place correctly.

08 Impreza & 09 Forester owners only: Use the larger 45mm washers at the top.

Offset CAB units should have the offset towards the center of the vehicle.

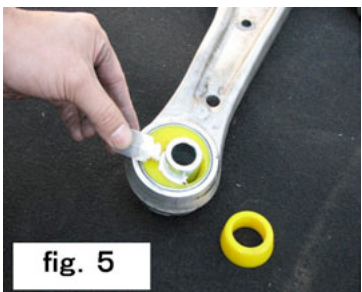
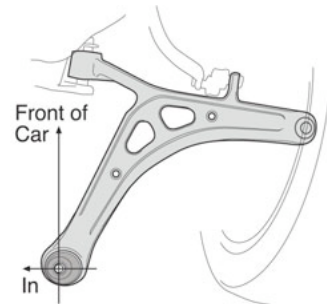

Grease the steel insert and press it into place in the center of the bushing. Then insert the smaller bushings over the steel insert. Make sure that the larger side of the small bushings are against the main bushing.

Re-bolt the control arm onto the vehicle in opposite order of the removal process. Make sure all bolts are tight.

Finally, get a professional front wheel alignment.

Job Done-Enjoy your car!

NOTE! – If in any doubt over the operation or installation of your parts contact AVOTurboworld, or official AVO distributor that you purchased the parts from.

AVO Turboworld LLC www.avoturboworld.com
phone: 425-835-0475 fax: 425-672-7872