

Installation Guide

ADJUSTABLE SWAYBAR LINKS

Z5146

(Always refer to the current catalogue for complete application listings)

N.B: This installation guide should be used in conjunction with the workshop manual.

1. Drive the vehicle up on ramps (if available) or alternatively raise the vehicle evenly on both sides and support with jack stands.
 2. Loosen and remove the existing OE sway bar links.
 3. Use a ruler or tape measure to check and confirm your OE link length.
 4. Please remember to leave at least 10mm of ball link thread in the lock nut, you can check this by completely removing the ball link and marking the thread. (REFER FIG 1)
 5. Once the length is determined, hand tighten all lock nuts with fingers. (REFER FIG 3)
- Note : Studs can point in any direction to suit application.
6. After installing one side check that the other link's studs line up with the sway bar and control arm holes. If you find the studs won't easily slide in then you now have the ability to fine tune the length of the adjustable ball link to remove any unwanted sway bar pre load.
 7. Once both links are installed and there are no visible clearance issues, then tighten all lock nuts with appropriate spanners.
 8. Check all fittings after test drive and recheck after initial 100km.

FIGURE 1

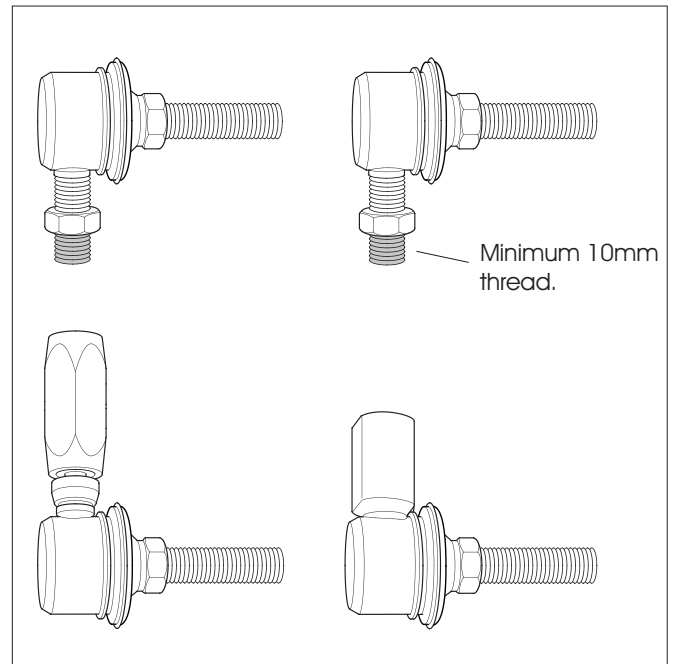

FIGURE 2

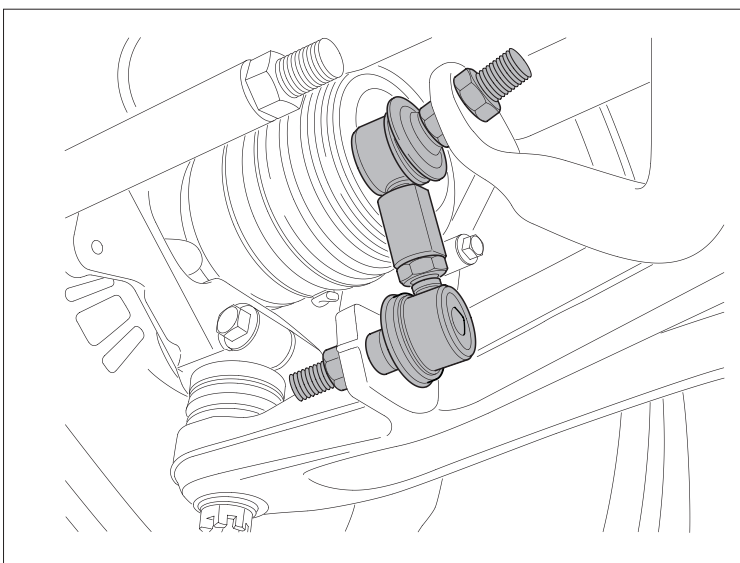
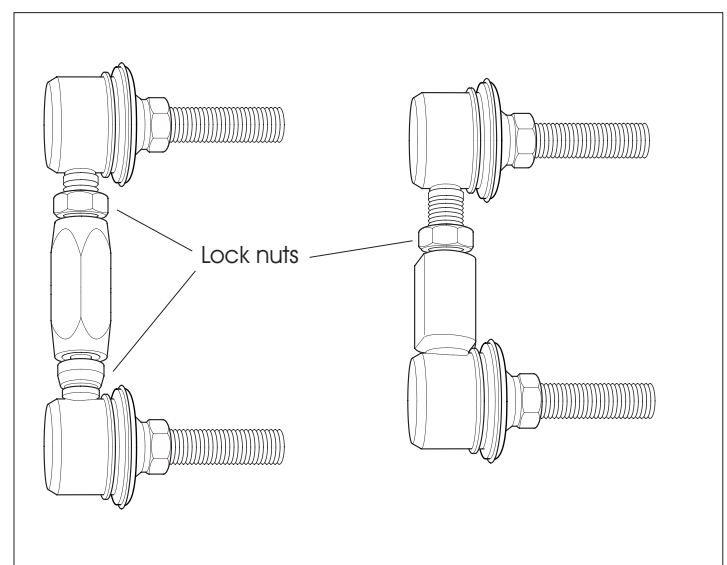

FIGURE 3



Warning: Please drive carefully after fitting any suspension modifications while you accustom yourself to the vehicles changed behaviour.

Note: It is recommended that a licensed workshop or trades person carry out the above procedure and that the workshop manual be used in conjunction with the above.

Installation Guide

Alloy Lateral Lock Kit

Z 5160

(Always refer to the current catalogue for complete application listings)

Alloy high performance lateral locks are designed to maintain Swaybar centralization.

1. Once you have your Swaybar in position and central with links attached, attach the lateral locks next to the mounting bush (leave approx 3-4mm gap). This can be either side of the mounting bush but its best to aim for the most accessible area on the Swaybar. If there is little room to physically tighten the lateral locks, it may be best to mark your Swaybar then remove from vehicle then attach the lateral locks prior to fitment.
2. Tighten the lateral lock bolts down evenly and use mild force to secure.
Note : Please don't over tighten.
3. After test driving the vehicle, recheck Swaybar position and adjust lateral locks if necessary.

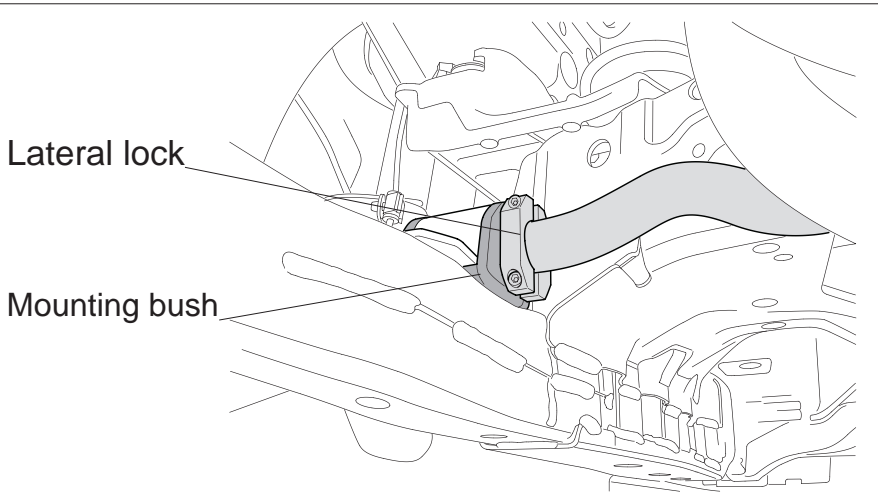

N.B: It is recommended that a licenced workshop or trades person carry out the above procedure and that workshop manual and relevant safety procedures are followed in addition to the above.

Instruction Sheet

Front Swaybar

Z5237

Suits: MAZDA MIATA NA

N.B: This instruction sheet should be used in conjunction with the workshop manual

INSTRUCTIONS

1. Raise vehicle evenly and safely support.
2. Remove OE front swaybar and links.
3. Generously grease the ID of the supplied D bushes.
4. Bolt the swaybar to the vehicle using the OE saddles.
5. Loosely bolt up the supplied links as per image below.
6. Centralize the swaybar and confirm there are no clearance issues.
7. Fit the supplied aluminium Lateral Locks (refer instructions Z5160).
8. Fine tune swaybar link lengths and tighten lock nuts (refer instructions Z5146).
9. Re check bolts after initial 100km travelled.

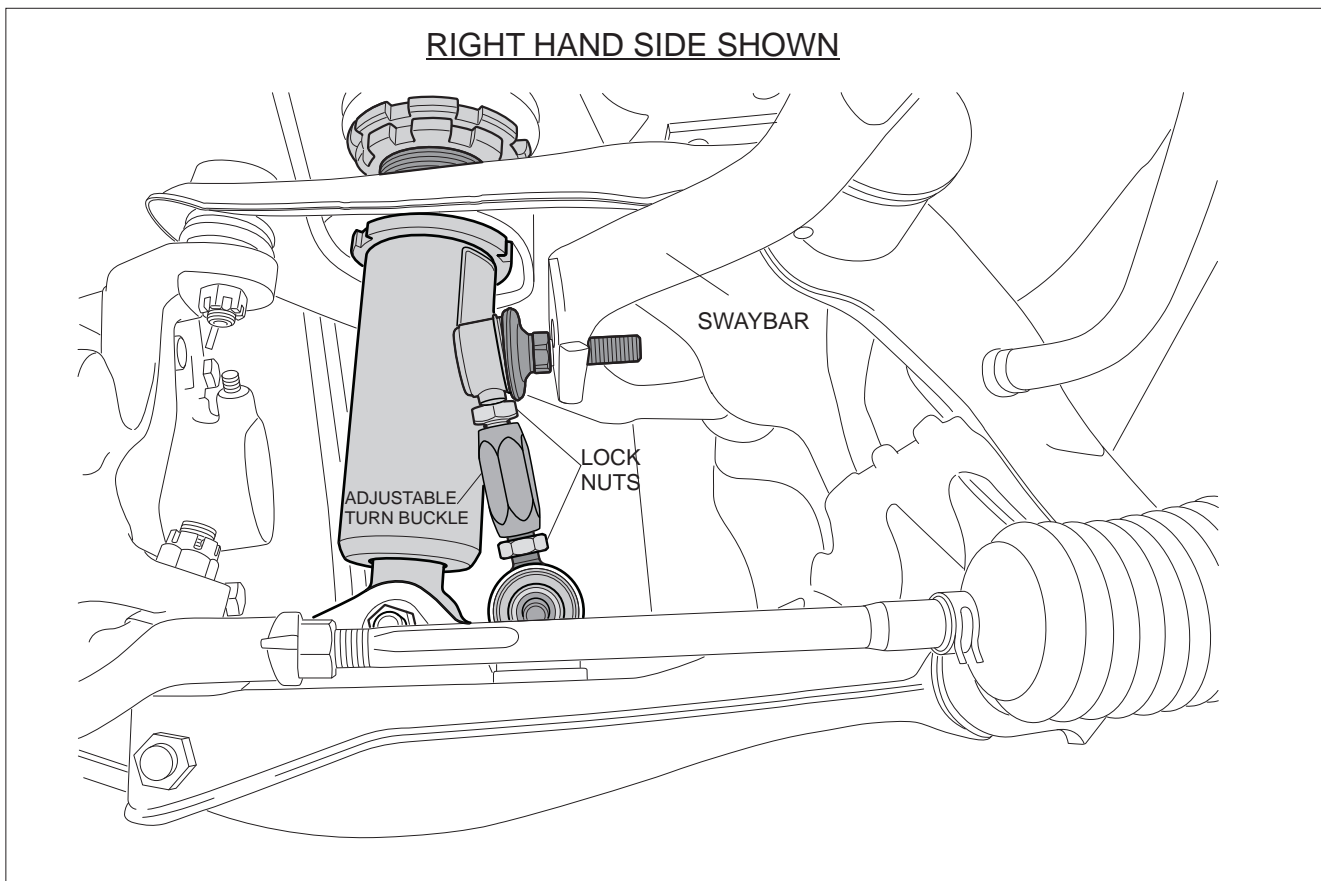

Warning: Please drive carefully while you accustom yourself to the changed vehicle behaviour.

N.B: It is recommended that a licenced workshop or tradesperson carry out the above procedure and that workshop manual and relevant safety procedures are followed in addition to the above.