



Installation Guide
VE/VF Commodores
FDFI OTR



VE/VF FDFI OTR

ENGINEERING PERFORMANCE SINCE 1955



For 60 years Harrop Engineering has been at the forefront of designing, developing and manufacturing precision performance components. Today our innovative and logical approach is applied to low volume automotive OEMs and the performance aftermarket through a dedicated team of 65 staff. Core performance products include Superchargers, Engine Components, Brakes, Differentials and we are also the exclusive Australian Distributor for Forgeline Motorsport Wheels & Lingenfelter Performance Parts.

Harrop are also the preferred supplier of Eaton Supercharger and Traction Control technology including dual branded product designed and manufactured in-house. There are currently over 4000 components in our portfolio and this is growing daily as we continually develop more Harrop Performance Products.

Our high profile car manufacturing customers include Holden, HSV, FPV, Roush and Lotus.

We also supply to race teams from categories including F1, NASCAR and V8 Supercars and an extensive range of drag, circuit and off-road competitors. Just as importantly, a large portion of our customers are performance enthusiasts and weekend warriors who are highly passionate about their ride.

Please take a moment to review the following pages and learn why Harrop is the first choice in performance products.

Thank you for choosing Harrop and enjoy your Harrop Enhanced ride.

- Team HARROP



VE/VF FDFI OTR

CONTENTS PAGE



Introduction	1
Car Preparation	3
VE PRE MY12 Radiator Positioning	3
VF & VE MY12 Radiator Positioning	6
Assembly and Installation of the MAFless OTR	8
Assembly and Installation of the FDFI OTR with MAF card	11



This document is meant only as a guide, as any vehicle modification should be completed by a certified technician who has the relevant experience and equipment to be competent of a safe and effective OTR installation.

Install Considerations

Before attempting installation, please review the notes below.

- VE GXP & HSV E2/3 with factory bonnet flutes can foul on OTR which may not allow the bonnet to close. Modification to bonnet may be required. Please contact the Harrop sales team before proceeding with installation for clarifications on fitment.
- VE commodores that have had the front radiator support changed may require VF mounting brackets for OTR & fascia panels, these parts can be supplied at additional cost.
- Aftermarket modifications could affect the installation of OTR - i.e - aftermarket radiator.
- FDFI supercharger with 110 throttle body snout fitted to supercharger will require different rubber boot.
- FDFI supercharger with LSA drive pulley with 85mm pulley and above can foul on inlet boot, OTR may require modification to suit if this size pulley is required.

1. Car Preparation

- 1.a. Removal of fascia panel where fitted.
- 1.b. Remove the intake duct.
- 1.c. Remove the standard MAF sensor.
- 1.d. Remove the standard air box.
- 1.e. Cut away 490mm of rubber seal from the inside of the bonnet as shown.

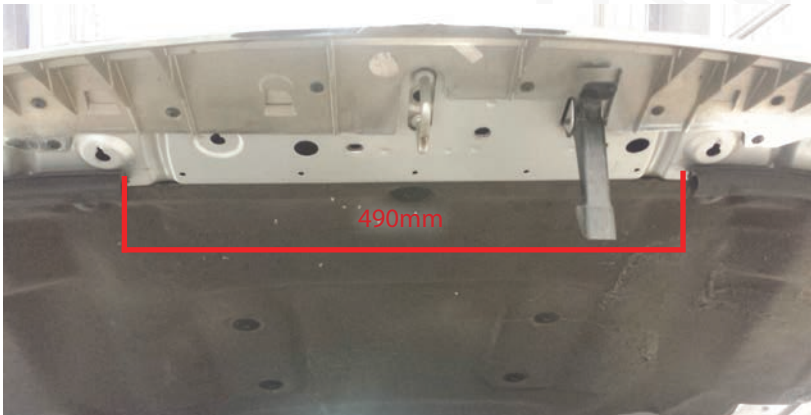

2. VE PRE MY12 Radiator Positioning

2.a. Remove the top two radiator mounts. To remove the upper radiator mounts, lift the locking clip up until it stops against its internal catch. Using a flat head screw driver depress the internal stop tab found on the LH side of the locking clip/plate and lift it out completely.

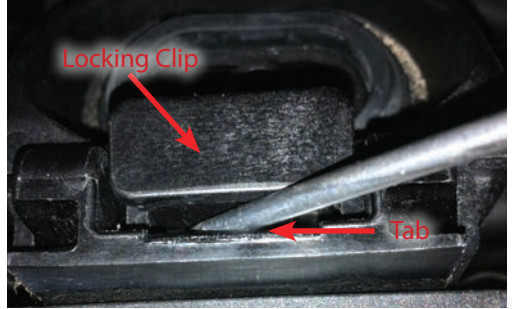

2.b. Using a flat screw driver, place it in the slot inside the top mount and lever the ratchet tab away far enough to unlock it and wiggle the mount upwards and remove.

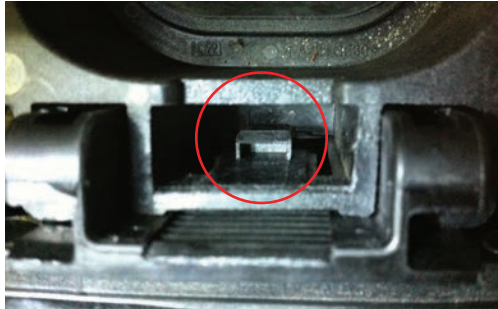

2.c. Remove the two lower sections of the mounts. Remove the 2 M6 bolts. Note: Retain the bolts to use with the OTR specific radiator brackets.

2.d. Use needle nose pliers or similar to compress the clips on the loom and push them through the lower section of the radiator mount. There are 2 clips for each mount.

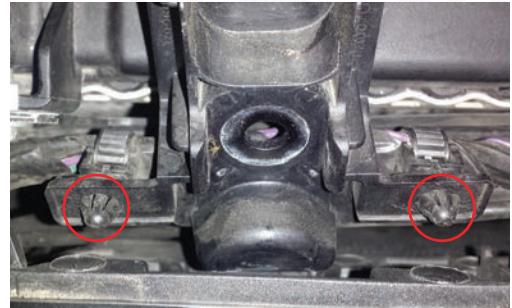

VE/VF FDFI OTR

INSTALLATION GUIDE



3.a. Remove the fastener that holds the condenser on to the radiator on the RH side of the car.



3.b. Push the radiator back towards the engine and install the RH VE OTR radiator bracket.

3.c. The OTR radiator bracket locates on the same mounting face as the standard radiator mount and holds the radiator at the condenser mount.

3.d. Use the existing screws from the standard radiator mount and the condenser to secure the new radiator bracket in place.

3.e. One of the 2 plastic clips on the loom can now be pushed into the remaining hole on the radiator bracket to hold the loom in place.



4.a. Remove the existing screws securing the condenser on to the radiator on the LH side of the car and repeat the process to install the LH VE OTR radiator bracket.

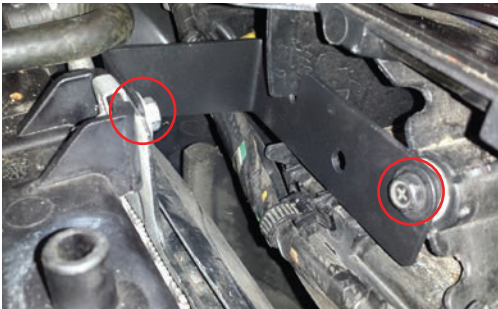

5. VF & VE MY12 Radiator Positioning

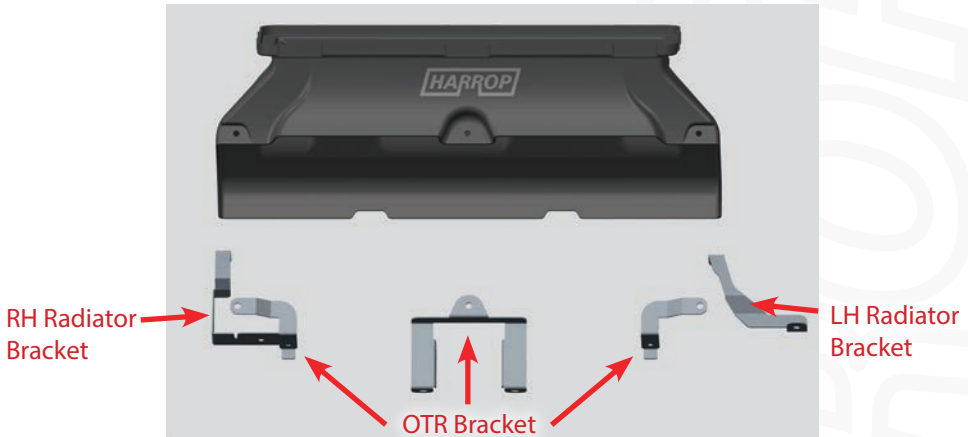

5.a. Remove the radiator mounts holding the top of the radiator in two places.

5.b. Remove the 2 M6 bolts holding the upper radiator mounts.

5.c. Push the radiator back to release the upper radiator mounts, remove upper radiator mounts.

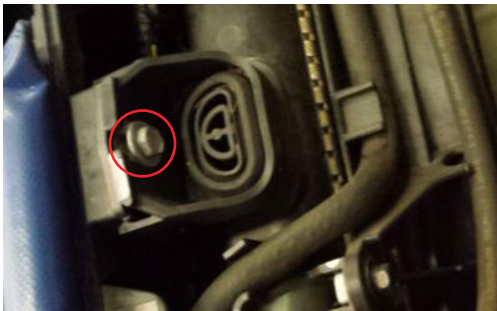

5.d. Remove the two lower sections of the mounts. Remove the 2 M6 bolts.

Note: Retain the bolts to use with the OTR specific radiator bracket



VE/VF FDFI OTR

INSTALLATION GUIDE



- 6.a. Remove the torx screw from the washer filler bracket.
- 7.a. Remove the fan screw from the rear LH of the radiator.
- 8.a. Position the LH radiator bracket as shown. Fit the screw back through the radiator bracket to secure the radiator bracket and fan.
- 8.b. The front of the bracket will slide in between the washer filler bracket and the radiator support panel. Insert the torx screw and tighten.



- 9.a For VF place the RH OTR bracket onto the mounting face for the standard radiator mount, place the RH radiator bracket over the OTR bracket as shown below. Push the radiator bracket down on top of the radiator to hold it in place. Fasten using the standard M6 bolt.
- Note: VE MY12 does not require the OTR brackets.



- 10.a. Fit the LH OTR bracket onto the mounting face for the standard radiator mounts.
- 10.b. Place the centre OTR bracket onto the back of the bonnet latch M8 bolts.
- 10.c. Fasten using the two nylock M8 nuts supplied in the bracket kit. (M8 bolts and washers supplied if required.)



11. Assembly and Installation of the MAFless OTR

- 11.a. Place boot over rear half of the OTR. Fasten with hose clamp #80 (117-140mm hose clamp).
- 11.b. Insert the duckbill drain and 2 grommets into the bottom front half of the OTR.
 - VE Pre MY12 uses grommets with internal diameter 13mm.
 - VF & VE MY12 uses grommets with internal diameter 20mm.

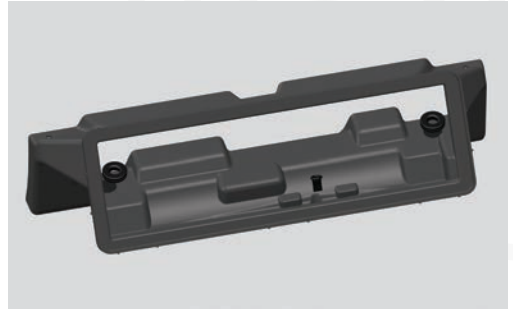
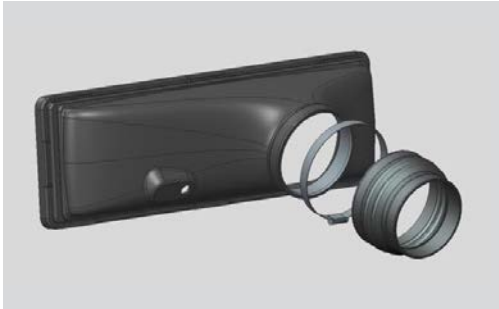

- 11.c. Place the filter into the rear of the OTR.
Note: The side of the filter with 3 steps should be placed into the back of the OTR.

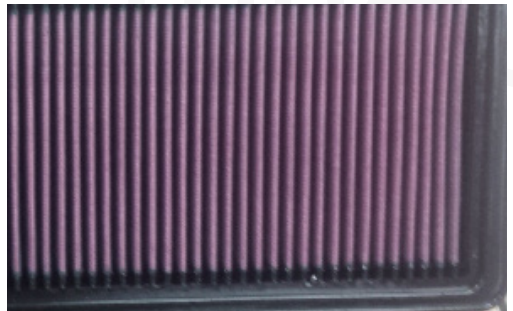

VE/VF FDFI OTR

INSTALLATION GUIDE



11.d. Place the front of the OTR over the rear of the OTR. Secure the two halves of the OTR together with the 8 spring clips, ensure they are centred in the clip pockets. (3 clips on the top, 3 on the bottom and 1 either side.)

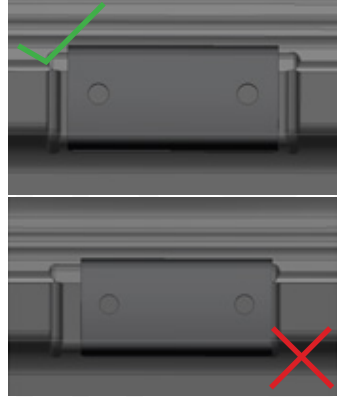

11.e. Insert the 2 quick connect fittings into the hose provided. Overall length 590mm (Use oil and or a heat gun to aid inserting the fittings into the hose.)

11.f. Connect supplied PVC hose to RH RC inlet and route in front of manifold as shown. (cable tie as necessary)



11.f. Install the throttle body into the rubber boot at the back of the OTR. Fit a 91-114mm hose clamp to back of OTR/boot but do not tighten.

12. Fit the OTR

12.a. Slide the OTR into the space between the radiator and the front bar.

Note: Hold the looms back as you insert the OTR to avoid catching the OTR on the looms.

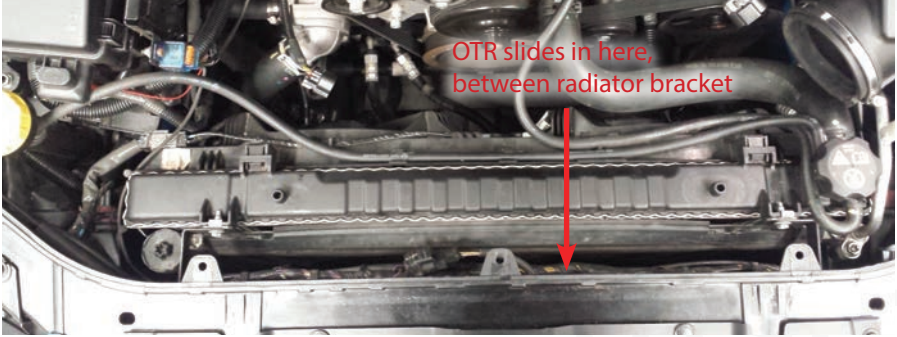

12.b. Align the grommet holes with the bosses on the radiator and gently push the OTR down until it is firmly seated on top of the radiator.

12.c. Screw the throttle body onto the supercharger using original bolts.

Note: Ensure throttle body O-ring is placed between throttle body and supercharger.

12.d. Connect the wiring harness to the throttle body.

12.e. Tighten hose clamp on the back of the OTR/boot.

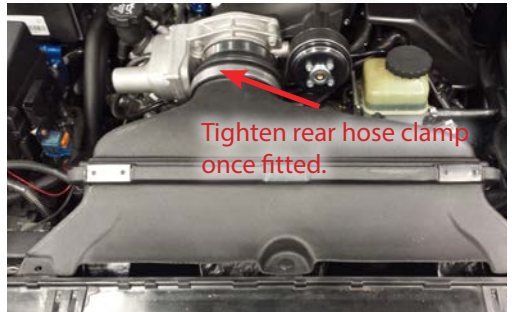

- 13.a. Connect the other end of the breather hose to the fitting in the back half of the OTR.
- 14.a. Push the 3 scrivenets through the top half of the OTR into the previously fitted brackets or standard mounts to hold the OTR in position.
- 15.a. Fit the MAF to IAT loom supplied.
- 16.a. Check OTR is secure, all hose clamps are tight, hoses are free from moving parts and all looms are connected.
- 17.a. VE-VF FDFI MAFless OTR install complete awaiting tune.

18. Assembly and Installation of the FDFI OTR with MAF card

- 18.a. Push the rubber boot over the rear of the FDFI OTR.
- 18.b. Spin it around so that the fitting hole in the boot is pointing at an angle of approximately 65 Degrees down to the RH side of the car from horizontal.

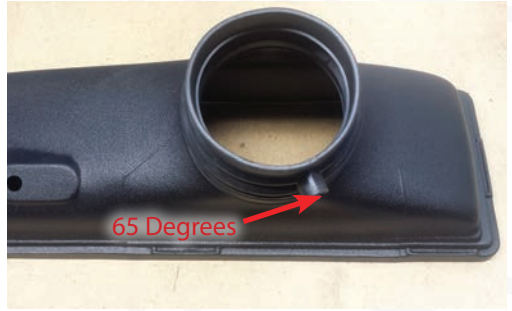

- 19.a. Insert the MAF tube assembly into the inside of the rubber boot from inside the rear of the OTR. Note: Some silicon spray may be required to push the tube into the rubber boot.



VE/VF FDFI OTR

INSTALLATION GUIDE



20.a. Fit a 117-140mm hose clamp to the boot but do not tighten at this stage.



21.a. Install the throttle body into the rubber boot at the back of the OTR.

21.b. Measure 22mm from the cast centre of the throttle body. Line up the hole on the rubber boot with the measurement.

21.c. Fit a 91-114mm hose clamp to back of throttle body/boot and fasten.



22.a. Remove the plastic cover from the loose MAF card connector. Use a small screw driver or similar to pick the two holes either side of the purple plastic cover and remove it.



VE/VF FDFI OTR

INSTALLATION GUIDE



22.b. Insert the MAF card loom through the quick connect fitting in the rear of the OTR.

22.c. Slide the rubber boot on the loom over the fitting so that it seals the rear of the OTR.



22.d. Insert the pins into the loom connector as shown.

22.e. Place the plastic cover back onto the connector



WIRE	CONNECTOR
YELLOW	A
RED	B
BLACK	C
EMPTY	D
EMPTY	E



23.a. Connect the loom to the MAF card.

Note: Pull the loom so that there is no loose wire inside the OTR.



24.a. Insert the 90 degree quick connect fitting into the rubber boot on the OTR.

Ensure the locating bead locks the fitting into position.

25.a. Fasten the fitting in place with the supplied 16mm green band cobra clamp.



VE/VF FDFI OTR

INSTALLATION GUIDE



- 26.a. Test fit the back section only of the OTR onto the supercharger. The 90 degree fitting should clear all of the pulleys. If not adjust as necessary.
- 27.a. Fasten the previously fitted 117-140mm hose clamp securing the boot and MAF tube to the rear section of the OTR.
- 27.b. Insert the duckbill drain and 2 grommets into the bottom front half of the OTR.
- VE Pre MY12 uses grommets with internal diameter 13mm.
 - VF & VE MY12 uses grommets with internal diameter 20mm.



- 28.a. Place the filter into the rear of the OTR.
Note: The side of the filter with 3 steps should be placed into the back of the OTR.



- 29.a. Place the front of the OTR over the rear of the OTR.
29.b. Secure the two halves of the OTR together with the 8 spring clips, ensure that they are centred in the clip pockets.

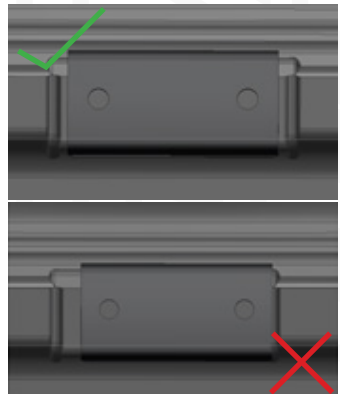

VE/VF FDFI OTR

INSTALLATION GUIDE



- 30.a. Cut 145mm from the supplied hose and push in two quick connect straight fittings, one each end. Overall length 215mm. (Use oil or heat gun to aid inserting the fittings into the hose.)
30.b. Push the new hose onto the breather pipe.

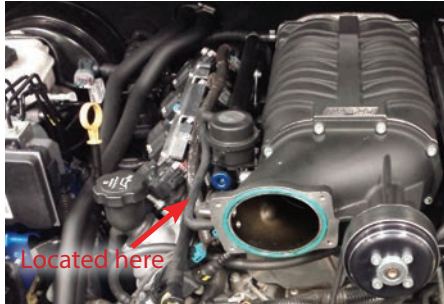

- 31.a. Slide the OTR into the space between the radiator and the front bar.
31.b. Align the grommet holes with the bosses on the radiator and gently push the OTR down until it is firmly seated on top of the radiator.

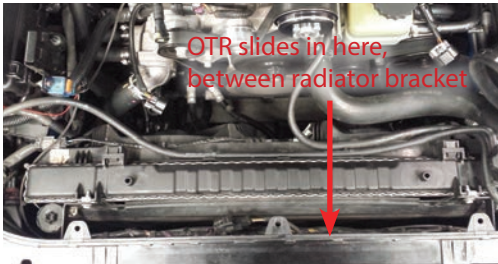

- 32.a. Reinstall the 4 M6 bolts holding the throttle body to the FDFI inlet.
33.a. Reconnect the throttle body loom.
34.a. Connect the other end of the breather hose to the 90 degree elbow fitting in the rubber boot, as shown below.
35.a. Connect the male MAF loom from the back of the OTR to the female MAF connector on the FDFI loom.



- 36.a. Push the 3 scrivers through the top half of the OTR into the previously fitted brackets or standard mounts to hold the OTR in position.
37.a. Check OTR is secure, all hose clamps are tight, hoses are free from moving parts and all looms are connected. OTR install complete awaiting tune.



Harrop Engineering

96 Bell Street
Preston, VIC
3072

e sales@harrop.com.au

t 03 9474 0900

w harrop.com.au

ENGINEERING PERFORMANCE SINCE 1955

HARROP

ENGINEERING PERFORMANCE SINCE 1955

WWW.HARROP.COM.AU