

## INSTALLATION INSTRUCTIONS

**69-8005**

**Subaru**

**2008-13 WRX STI**

**H4-2.5L**

**NOTE: C.A.R.B. E.O. # D-269-37  
APPLIES ONLY TO 2008-10 MODEL  
YEAR VEHICLES**

**TOOLS NEEDED:**

3mm Allen Wrench  
10mm Socket  
10mm Wrench  
Extension  
Flat Blade Screwdriver  
Phillips Screwdriver  
Ratchet

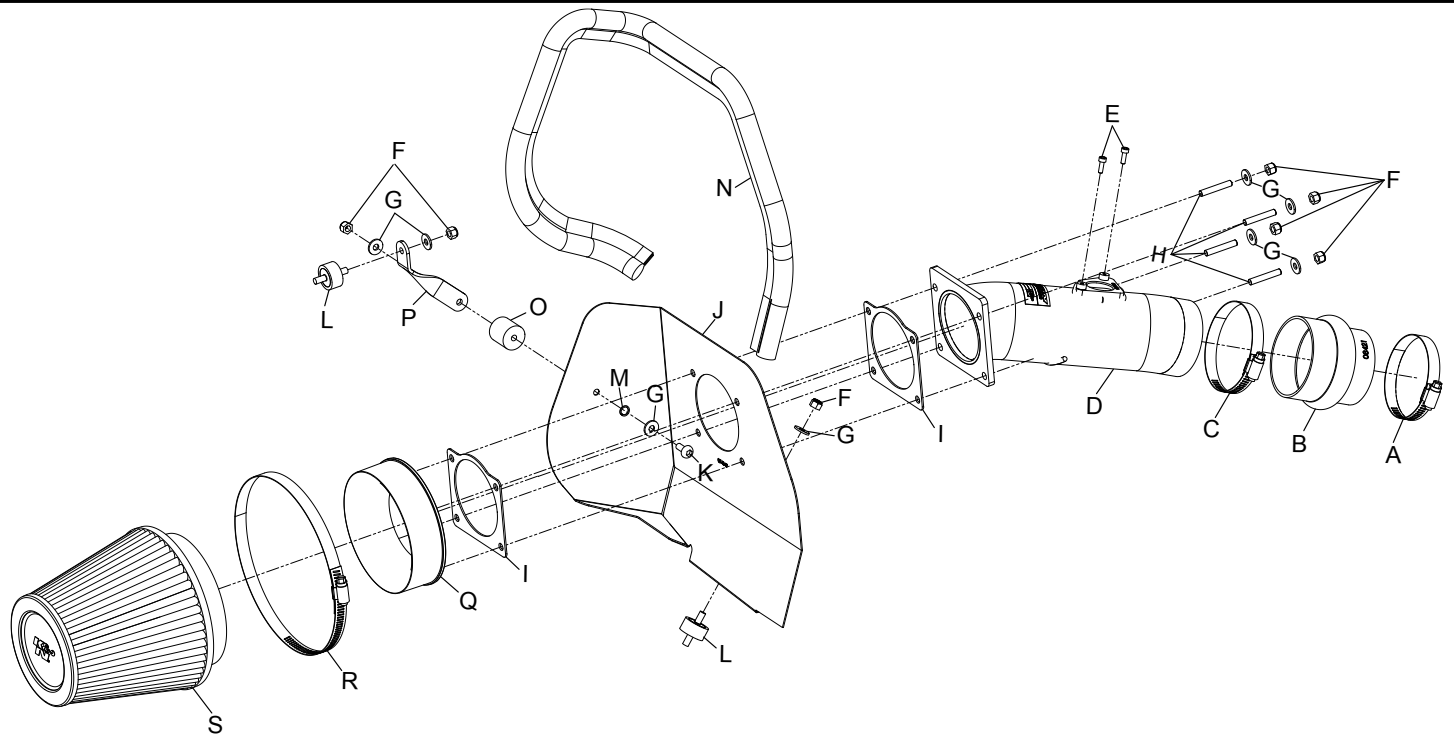

**PARTS LIST:**

Description	Qty.	Part #	Description	Qty.	Part #	Description	Qty.	Part #
A Hose Clamp #44	1	08560	H Stud; 6MM-1.00 X 35MM L, SS	4	08220	O Stud; Mount, M6 X 1, 1" T, M/F	1	02033
B Hose; 3" TO 2-3/4" X 3" L Hump	1	08421	I Gasket; 1/16" Neoprene	2	09202	P Bracket; SM. Mild STL, FB/PC	1	07139
C Hose Clamp #48	1	08601	J Heat Shield	1	074047	Q Adaptor; #350	1	21510
D Intake Tube	1	27554	K Bolt; M6 X 1.00 X 16MM, SS	1	07730	R Hose Clamp #80	1	08694
E Bolt; M4 - 0.07 8MM, A/H CAP, SS	2	07733	L Stud; M6-1.00 M/M, Mntd	2	07027	S Air Filter	1	RP-5113
F Nut; 6MM Nylock, Hexhead, SS	7	07512	M Washer; 1/4" Lock, ZN	1	08198			
G Washer; 6MM Flat, SS	8	08269	N Edge Trim (35")	1	102471			

**NOTE: FAILURE TO FOLLOW INSTALLATION INSTRUCTIONS AND NOT USING THE PROVIDED HARDWARE MAY DAMAGE THE INTAKE TUBE, THROTTLE BODY AND ENGINE.**

**TO START:**

1. Turn off the ignition and disconnect the negative battery cable.

**NOTE: Disconnecting the negative battery cable erases pre-programmed electronic memories. Write down all memory settings before disconnecting the negative battery cable. Some radios will require an anti-theft code to be entered after the battery is reconnected. The anti-theft code is typically supplied with your owner's manual. In the event your vehicles' anti-theft code cannot be recovered, contact an authorized dealership to obtain your vehicles anti-theft code.**

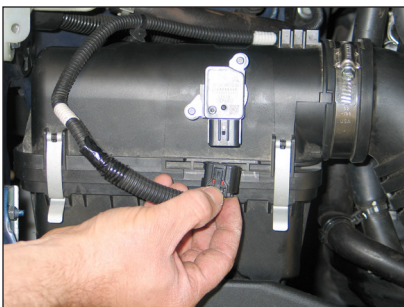

2. Disconnect the mass air sensor electrical connection.



3. Remove the two clips that retain the fresh air inlet duct. Then remove the fresh air inlet duct from the vehicle.

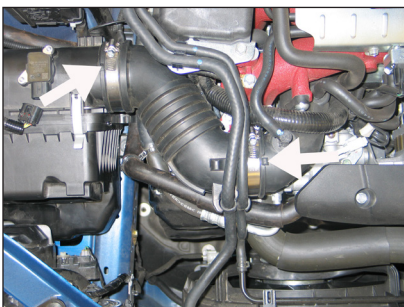

4. Loosen the two hose clamps that secure the stock intake tube.



5. Remove the stock intake tube from the vehicle.

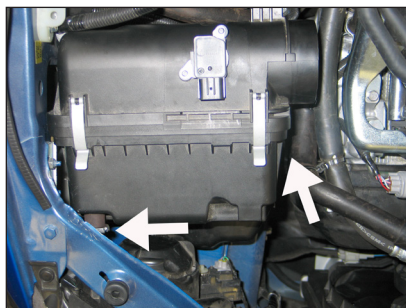

6. Remove the bolt and nut that secure the stock air filter housing.



7. Remove the stock air filter housing from the vehicle.

**NOTE: K&N Engineering, Inc., recommends that customers do not discard factory air intake.**



8. Remove the front P/S reservoir mounting bolt shown.



9. Install the provided short, m/m rubber mounted stud into the P/S reservoir as shown.

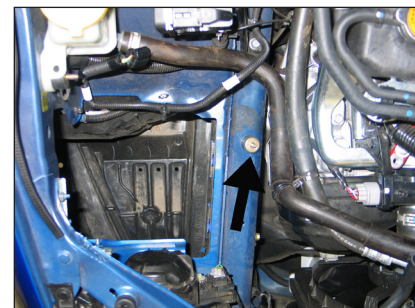

10. Install the provided short m/m rubber mounted studs into the airbox mounting location on the frame rail.



11. Install the provided silicone hose (08421) onto the turbo inlet and secure with the provided hose clamps.



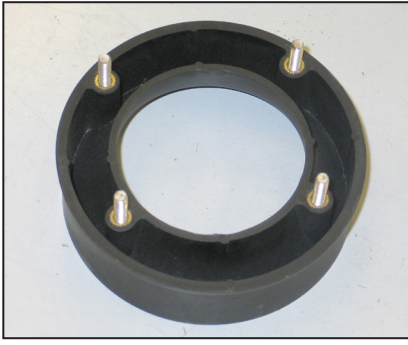

12. Install the four 6mm studs into the filter adapter as shown.



13. Install the filter adapter assembly into the K&N® air filter and secure with the provided hose clamp.



14. Install one of the provided gaskets onto the filter adapter as shown.

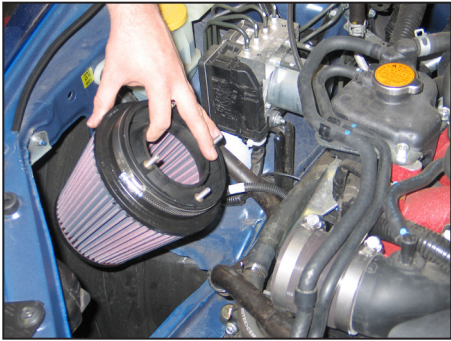

15. Set the filter assembly into the fender in preparation for the heat shield installation.

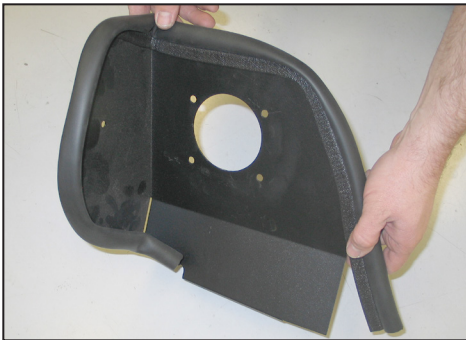

16. Install the provided edge trim onto the heat shield as shown.

**NOTE: Some trimming of the edge trim will be necessary.**



17. Install the long, m/f rubber mounted stud onto the heat shield mounting bracket (07139) as shown.



18. Install the heat shield mounting bracket assembly onto the heat shield as shown and secure with the provided hardware.

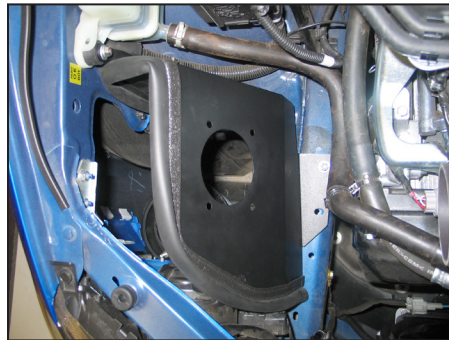

19. Install the heat shield assembly into the vehicle and secure to the rubber mounted studs with the hardware provided.

**NOTE: The front mounting hole is not used on this model vehicle.**

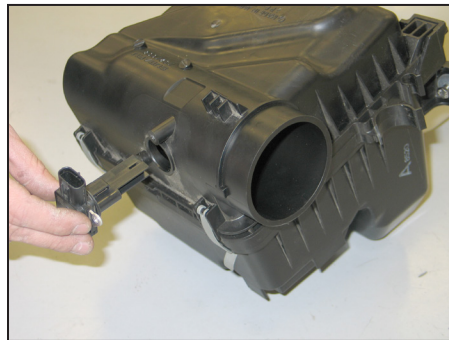

20. Remove the mass air sensor from the stock airbox as shown.

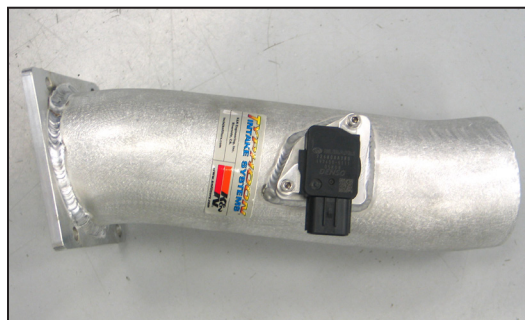

21. Install the mass air sensor into the K&N® intake tube and secure with the provided hardware.



22. Install the K&N® intake tube into the silicone hose at the throttle body as shown.



23. Install the filter so that the mounting studs pass through the heat shield, two gaskets, and intake tube flange and then secure with the provided hardware.

**NOTE: Be sure to place one of the provided gaskets between the intake tube mounting flange and heat shield.**



24. Reconnect the mass air sensor electrical connection.



25. Reconnect the vehicle's negative battery cable. Double check to make sure everything is tight and properly positioned before starting the vehicle.

26. The C.A.R.B. exemption sticker, (attached), must be visible under the hood so that an emissions inspector can see it when the vehicle is required to be tested for emissions. California requires testing every two years, other states may vary.

27. It will be necessary for all K&N® high flow intake systems to be checked periodically for realignment, clearance and tightening of all connections. Failure to follow the above instructions or proper maintenance may void warranty.

#### ROAD TESTING:

1. Start the engine with the transmission in neutral or park, and the parking brake engaged. Listen for air leaks or odd noises. For air leaks secure hoses and connections. For odd noises, find cause and repair before proceeding. This kit will function identically to the factory system except for being louder and much more responsive.

2. Test drive the vehicle. Listen for odd noises or rattles and fix as necessary.

3. If road test is fine, you can now enjoy the added power and performance from your kit.

4. K&N Engineering, Inc., requires cleaning the intake system's air filter element every 100,000 miles. When used in dusty or off-road environments, our filters will require cleaning more often. We recommend that you visually inspect your filter once every 25,000 miles to determine if the screen is still visible. When the screen is no longer visible some place on the filter element, it is time to clean it. To clean and re-oil, purchase our filter Recharger® service kit, part number 99-5050 or 99-5000 and follow the easy instructions.

**STREET LEGAL IN MOST STATES**

**NOT LEGAL FOR USE IN CA & OTHER STATES ADOPTING CA EMISSIONS STANDARDS**

See our catalog or [knfilters.com](http://knfilters.com) for CARB status on each part for a specific vehicle

\* FREE K&N® decal To register your warranty, please see us online at [knfilters.com/register](http://knfilters.com/register). FREE K&N® decal \*

• 1455 CITRUS ST., P.O. BOX 1329, RIVERSIDE, CA., U.S.A. 92502 • TECH SERVICE 800-858-3333 • FAX 951-826-4001  
• e-mail: [tech@knfilters.com](mailto:tech@knfilters.com) • WWW: <http://www.knfilters.com>