

advanced FLOW engineering

Instruction Manual P/N: 52-76305 / 51-76305 / 54-76305

Make: BMW Model: M3 (F80)	Year: 2015-2018	Engine: L6-3.0L (tt) S55
Make: BMW Model: M4 (F82/F83)	Year: 2015-2019	Engine: L6-3.0L (tt) S55
Make: BMW Model: M2 (F87)	Year: 2019	Engine: L6-3.0L (tt) S55



- Please read the entire instruction manual before proceeding.
- Ensure all components listed are present.
- If you are missing any of the components, call customer support at 951-493-7100.
- Ensure you have all necessary tools before proceeding.
- Do not attempt to work on your vehicle when the engine is hot.
- Disconnect the negative battery terminal before proceeding.
- Retain factory parts for future use.

Label	Qty.	Description	Part Number
A1	2	Air Filter (Pro DRY S)	21-91097
A2	2	Air Filter (Pro 5R)	24-91097
B	2	Clamp 2-9/16" - 3-1/2"	03-50007
C	1	Grommet, Air Temp Sensor	03-50033
D	4	Screw, Chs Hd Slotted M4x0.7x10	03-50221
E	4	Screw, Button Head M4x0.7x6	03-50409
F	2	Plug, urethane	05-01225
G	1	Fitting, Vacuum line	05-01246
H	1	Coupling, Silicone Elbow	05-01334
I	1	Tube, Driver Side	05-76305B1
J	1	Tube, Passenger Side	05-76305B2
K	1	Housing, Driver Side	05-76305B3
L	1	Housing, Passenger Side	05-76305B4
M	1	Cover, Carbon Fiber	05-76305C5

Tools required: 7mm, 8mm Nut driver, 10mm Nut Driver, 1/4" Ratchet, 10mm, 13mm Socket, Flathead Screw Driver, Pliers.

Note: Legal in California for use on race vehicles only. The use of this device on vehicles used on public streets or highways is strictly prohibited in California and others states that have adopted California emission regulations.

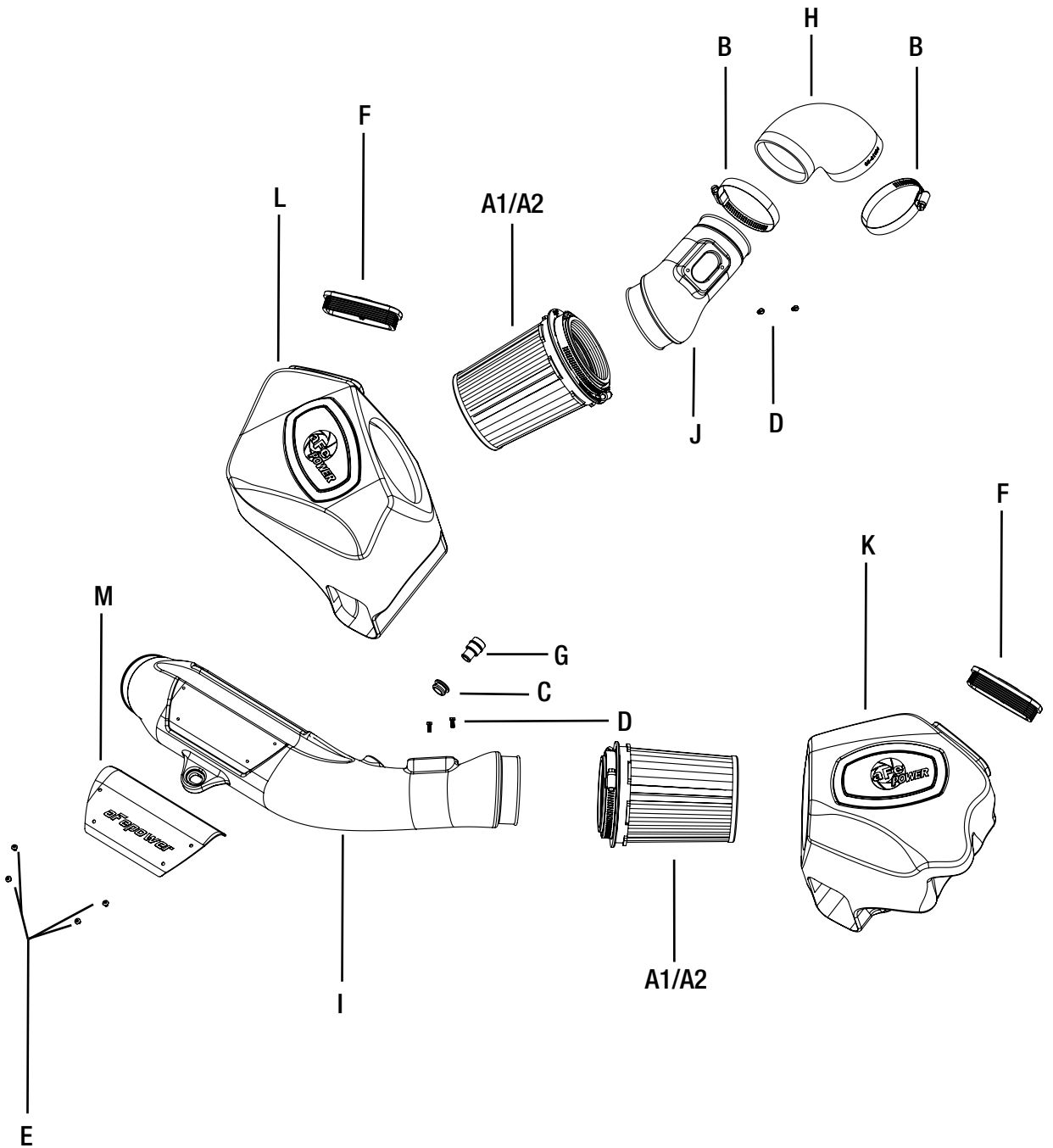

**Figure A****Refer to Figure A for Steps 1-3**

- Step 1: Remove the push clip (1) on the driver and passenger side windshield cover.
- Step 2: Unlock the three 10mm plastic nuts (2) retaining the windshield covers on the driver and passenger side.
- Step 3: Remove the windshield covers (3) on the driver and passenger side.



Figure B

Refer to Figure B for Steps 4-5

Step 4: Remove the 8 bolts (4) securing the carbon fiber strut brace. Remove 10mm bolt (5) securing strut bar to reservoir.

Step 5: Remove the carbon fiber front strut brace.



Refer to Figure C for Steps 6-8

Step 6: Disconnect the MAF sensor (6) on driver side intake tube.

Step 7: Disconnect vacuum line (7) and unclip coolant hose routed on top of intake tube.

Step 8: Loosen clamp at turbo and unclip tube from front mounting bracket, then pull the full driver side intake system out of the vehicle. Remove the small rubber gasket (8) on the front mounting bracket.

**Figure D****Refer to Figure D for Steps 9-11**

Step 9: Disconnect the MAF sensor (9) on the passenger side air box.

Step 10: Loosen the clamp between the air box and the 90 degrees tube. Pull the air box out of the vehicle.

Step 11: Loosen the clamp between the 90 degrees tube and the turbo inlet tube. Remove the 90 degrees tube out of the vehicle.

**Figure E****Refer to Figure E for Steps 12-14**

- Step 12: Decide if you want to use the dry or oiled filters. Slide the selected filters inside the aFe housings until they lock in place. Install clamps on filters' ends but do not tighten at this time.
- Step 13: Install driver side aFe housing into the vehicle. Push it firmly into the factory mounting grommets.
- Step 14: Transfer factory mounting grommet ⑩ from bottom of passenger side factory housing to the bottom of the aFe housing. Install the passenger side housing onto the vehicle. Orient the mounting grommet at the bottom correctly to make sure it secures over the sheet metal. Then push the housing firmly into the other factory mounting grommet.



Figure F

Refer to Figure F for Steps 15-16

Step 15: Transfer driver side MAF sensor from the factory air box to the long aFe tube. Secure it with the furnished M4 screws.

Step 16: Install the furnished grommet into the hole on the aFe tube, then push the aluminum fitting in.

**Figure G****Refer to Figure G for Steps 17-20**

Step 17: Install the driver aFe tube in the vehicle. Slide the tube end into the factory turbo inlet tube then the other end into the filter.

Step 18: Clip the aFe tube to the factory mounting bracket at the front of the car. Align tube correctly then tighten clamps on both ends.

Step 19: Connect the vacuum line to the aluminum fitting. Re-connect the MAF sensor harness.

Step 20: Place the coolant hose onto the tube. Install the carbon fiber cover over the tube and coolant hose. Secure it with the 4 button head screws provided.



Figure H

Refer to Figure H for Steps 21-24

Step 21: Transfer the passenger side MAF sensor to the short aFe tube.

Step 22: Install the 90 degrees furnished coupling over turbo inlet tube. Install clamps but do not tighten at this time.

Step 23: Install short aFe tube into vehicle. Slide small end into coupling then other end into filter. Align tube correctly then tighten all clamps.

Step 24: Reconnect MAF sensor harness.

**Figure I****Refer to Figure I for Steps 24-28**

Step 25: Re-install the carbon fiber strut brace and bolts. Tighten them firmly. Make sure not to lock or squeeze the hood cable. Re-install windshield covers and clips.

Step 26: Make sure all clamps and screws are tight.

Step 27: If desired, install the furnished plugs onto the extra air inlet openings of the aFe housings to close them off. This will protect the filters from the hot air in the engine compartment and will also make the intake quieter.

Step 28: Your installation is now complete. Thank you for choosing aFePower.

***Verify all connections are secure 100-200 miles after installation**

Page left blank intentionally



Pro DRY S Air Filter



P/N: 21-91097

Pro 5R Air Filter



P/N: 24-91097

Pro DRY S Restore Kit



P/N: 90-59999

Blue Squeeze Restore Kit



P/N: 90-50501

SCORCHER GT Module



P/N: 77-46310

Twisted Steel Downpipes



P/N: 48-36312-1 (Street)
48-36313 (Race)

Intercooler Chargepipes



P/N: 46-20198-B

Dry C/F Engine Cover



P/N: 79-13003

DP-Back Exhaust System



P/N: 49-36337-C (C/F Tips)
49-36337-P (Pol Tips)

Axle-Back Exhaust System



P/N: 49-36338-C (C/F Tips)
49-36338-P (Pol Tips)

Sprint Booster V3



P/N: 77-16302

To purchase any of the items above, view airflow charts, dyno graphs, photos, and video; please go to aFepower.com.

Warranty

General Terms:

- aFe warrants their products to be free from manufacturer's defects due to workmanship and material.
- This warranty applies only to the original purchaser of the product and is nontransferable.
- Proof of purchase of the aFe product is required for all warranty claims.
- Warranty is valid provided aFe instructions for installation and/or cleaning were properly followed.
- Proper maintenance with regular inspections of product is required to insure warranty coverage.
- Damage due to improper installation, abuse, unauthorized repair or alteration is not warranted.
- Incidental or consequential damages or cost, including installation and removal of part, incurred due to failure of aFe product is not covered under this warranty.
- All warranty is limited to the repair and/or replacement of the aFe part. To request Return Goods Authorization ("RGA"), email RGA@afepower.com or call (951)493-7100. Upon receipt of the RGA, you must return the product to the address provided in the RGA, freight prepaid and accompanied with a dated proof of purchase and the RGA. Upon receipt of the defective product and upon verification of proof of purchase, aFe will either repair or replace the defective product within a reasonable time, not to exceed thirty days.

Product Category	P/N Prefix	Warranty duration
Direct OE Replacement Filters	10, 11, 30, 31, 71, 73	Life of the vehicle
Racing Filters	18	1 year
Universal	21, 24, 72	2 years
Air Intake Systems	50, 51, 54, 55, 75	2 years
Exhaust Systems	49	2 years
Intercoolers & Intercooler Tubes	46-2	2 years
Intake Manifolds	46-1	2 years
Differential Cover	46-7	Life of the vehicle
Exhaust Manifolds	46	2 years
Throttle Body Spacers	46-3	2 years
Fluid Filters	44	90 days
Pre-Filters	28	2 years
Heavy Duty OE Replacement	70	2 years
PowerSports OE Replacement	81, 87	2 years
PowerSports Intake Systems	85	2 years

No other warranty expressed or implied applies nor is any person or advanced FLOW engineering authorized to assume any other warranty. Some States do not allow the exclusion or limitation of incidental or consequential damages or do not allow limitations on how long an implied warranty lasts, so the above limitations or exclusions may not apply to you. This warranty gives you specific legal rights, and you may also have other rights which vary from State to State.



advanced FLOW engineering, inc.
252 Granite Street Corona, CA 92879
TEL: 951.493.7100 • TECH: 951.493.7134
E-Mail: Tech@aFepower.com