



# INSTALLATION INSTRUCTIONS

## RADIUM Fuel Rail

## BMW S54 Engine

Document# 19-0053

Support: [info@radiumauto.com](mailto:info@radiumauto.com)

1. There are 2 common ways to relieve fuel pressure.

Option 1: Open glove compartment. Rotate the 2 white tabs on the top-inside of the glove box in order to release and swing the fuse box down. To temporarily disable the fuel pump, remove fuse 54. Start vehicle and allow engine to stall. Turn off car and remove key. Reinstall fuse and glove box.

Option 2: There is a Schrader bleed valve found on the factory FPR underneath the vehicle, shown at right.

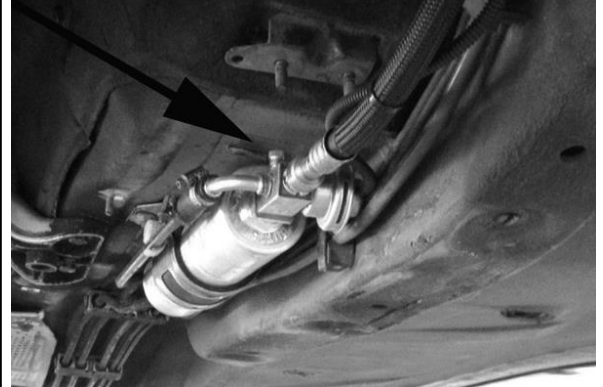

2. Caution: Disconnecting the battery (G1) may cancel the fault memories of some control units. Consequently, before disconnecting the car's battery, always interrogate the fault memories. Investigate stored faults and, once any faults have been remedied, cancel the fault memory.

Open the trunk. Remove the right side trunk paneling to gain access to the battery. Unscrew and disconnect the negative terminal.



3. Open hood.

Disengage quarter-turn fasteners (1) and remove the interior ventilation filter cover (2).

Remove micro filter element.

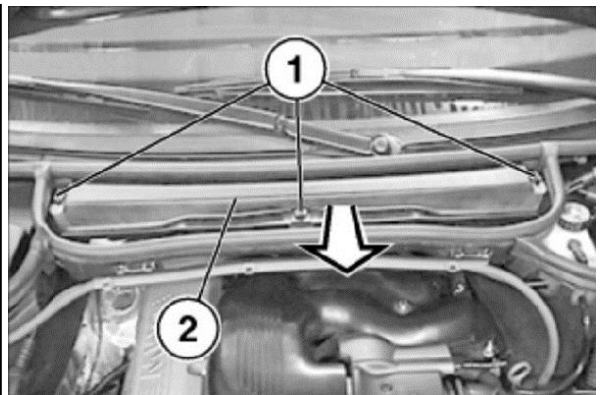

4. Unclip the 4 tabs (shown) for the cable duct in front of the cowl and separate the two long pieces.

Make sure the engine is cool. Pull the large cables out of the plastic retaining seats and gently lay them down on the engine.

Unscrew the four 13mm hex nuts and remove the BMW strut bar.

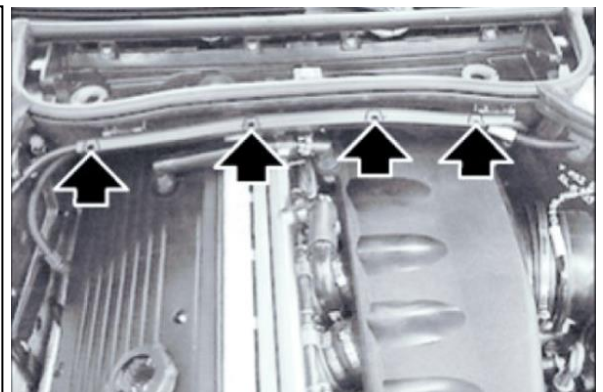

5. Unscrew four T30 Torx bolts (1) and remove lower section of micro filter housing (2) by pulling towards the front of vehicle.

Locate the PCV hose that attaches the valve cover to the intake manifold. Squeeze each plastic PCV connector end and pull upwards. Note: Some later models have an additional connection on the vacuum rail (not shown). Locate the large idle air motor connection to vacuum rail. Squeeze the plastic connector and pull away. Rotate out of the way.

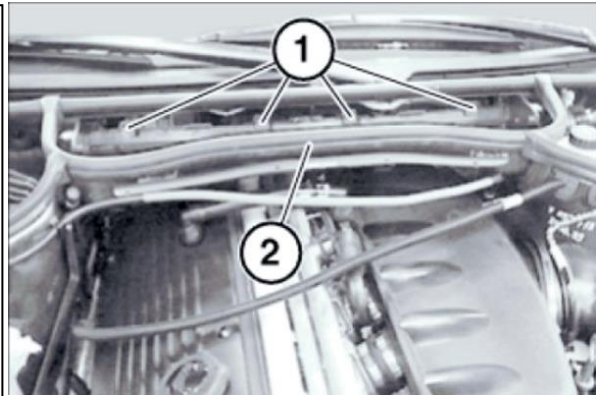

6. Towards the back of the vacuum rail there is a barbed nipple.

There is a short 90degree rubber hose and corresponding hard plastic tube that connects the vacuum rail to the fuel pressure regulator located next to the fuel filter underneath the vehicle.

Pull the short rubber hose off the vacuum rail.

Be careful not to lose the hard plastic tube which will be zip-tied in place by BMW.



7. Because the new big bore fuel rail takes up more space, the barbed nipple will need to be slightly modified.

Using a small closed end wrench, carefully pry and bend the barb upwards slightly without putting stress on the brazed weld.

It does not need to be moved very much.

We recommended doing this step conservatively and potentially in multiple steps.



8. Unplug the TPS connector on the end of the individual throttle body assembly located towards the front of the vehicle.

To unclip the electrical injector plastic rail, BMW sells a special tool (12 1 120) BMW P/N 83300493902, shown at right.

If this tool is not available, a simple pick can be used to pry the metal clips outwards on each injector. Use the sequence, shown at right, and gently pull the plastic rail towards the engine cover.

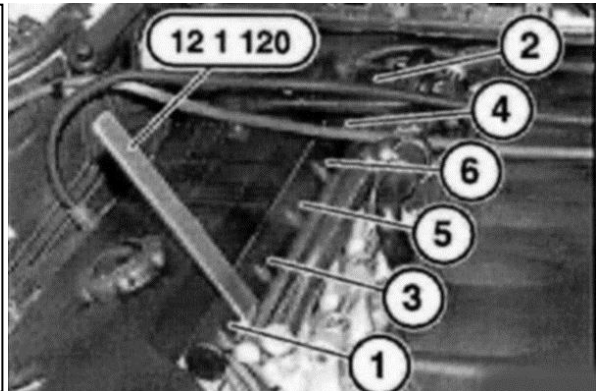

9. The vacuum rail must also be removed from its seat. For this, it is NOT necessary to remove the large brake booster hose.

Unscrew the two 10mm hex head M6 x 1 x 25mm bolts on each end of the rails (front bolt shown at right). These will be reused.

Cautiously, pull the vacuum rail upwards without losing the 6 aluminum vacuum spacers. Confirm all O-rings are still in place. The vacuum rail should be able to rotate around (with brake booster hose attached) and placed onto the intake manifold.

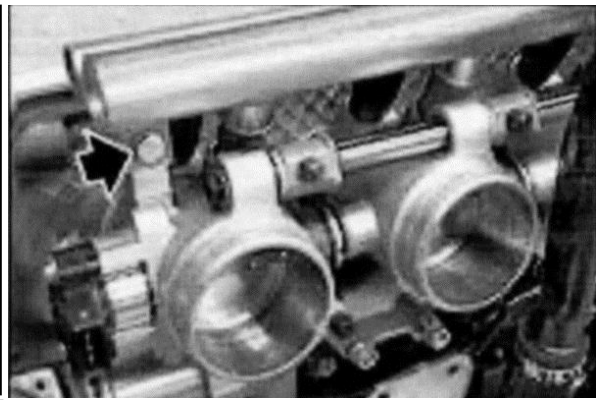

10. The feed pipe is between injector 5 and injector 6. Carefully pull the C-clip (1) off. Note: the retaining clip will NOT be reused with the Radium rail.

Next, gently lift the fuel rail upwards. The injectors will remain on the factory fuel rail. Surround the area with shop towels to absorb the remaining fuel contained in the pipe and rail.

Temporarily plug all 6 injector ports on the individual throttle body assembly to avoid fuel contamination. It is advised to plug (or tape over) all 6 cylinder intake ports to prevent objects from falling down into the engine.

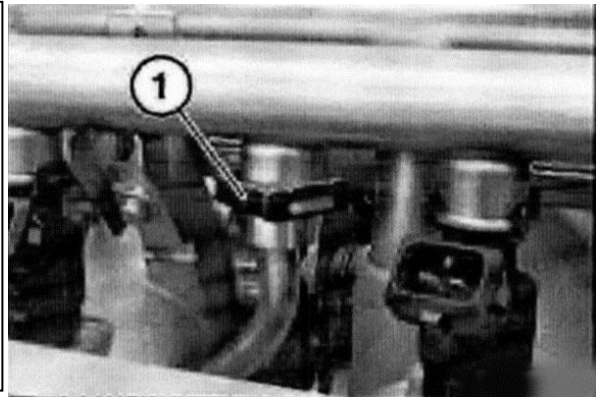

11. Confirm all of the injector O-rings are still attached to the bottom of the injectors.

To remove all 6 injectors from the factory rail, first disconnect all 6 injector retaining clips, pointed out in picture at right.

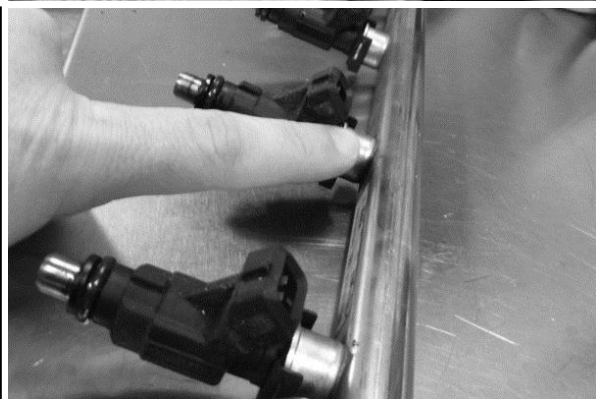

12. Note: The factory injector retaining clips (1) will NOT be reused with the Radium fuel rail.

Carefully remove the 6 fuel injectors from the factory fuel rail by gently pulling away from the fuel rail (2).

Disassembly is complete.

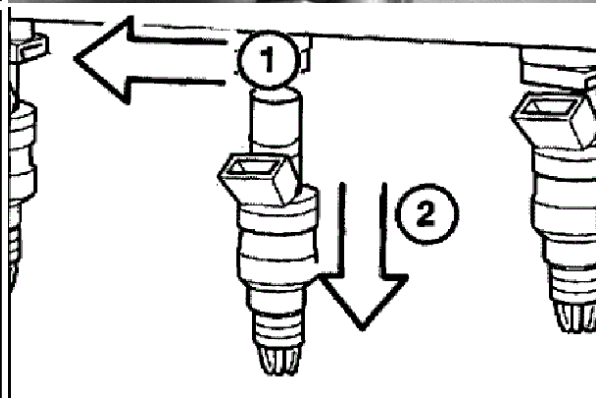

13. Apply a medium strength thread locker to the included socket head bolts. Next, secure the 2 mounting feet to the rail with a 4mm Allen wrench.

Mount the adapter fittings to the fuel rail ends. **To prevent failure, lubricate all O-rings prior to assembly.**

Because the center port uses 3/8" NPT tapered threads, apply Teflon paste to the thread of the fitting used.

If the Radium fuel pressure gauge was purchased, apply Teflon paste to the gauge's 1/8" NPT tapered threads as well.

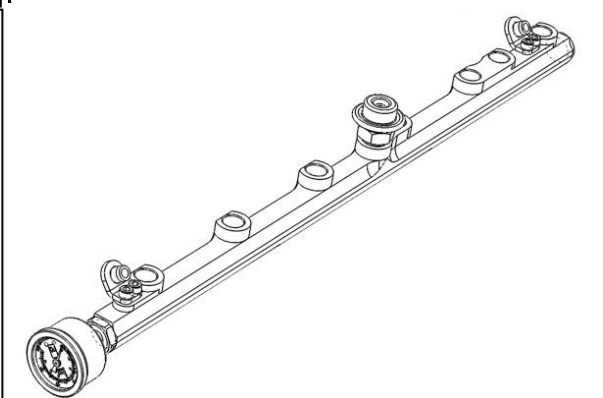



14. Before inserting the fuel injectors into the Radium fuel rail, clean and lubricate all O-rings with clean oil.

Install the fuel injectors into the Radium fuel rail ports being careful not to damage the O-rings.

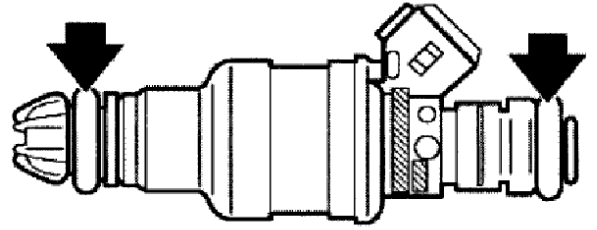

15. The factory feed pipe will NOT be reused for a feed (or return) port. However, the Radium fuel rail can be installed with the OEM fuel hard line installed physically to the engine block. There is a recess machined into the bottom side of the Radium fuel rail specifically for this, as shown.

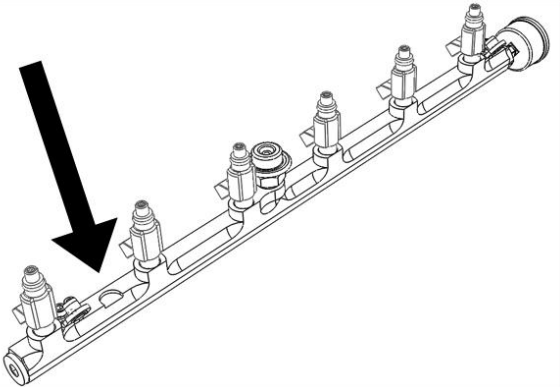

16. For 2005-2006 models that have a PCV solenoid mounted on the vacuum rail, slightly pry the 2 mounting tabs (shown) back ~1mm as they may come in contact with the top of the rail.

Also shown is the vacuum nipple clearance from Step 7.

Reinstall fuel rail components in reverse order.



17. If installing a "20-0070-00 OEM Configuration Kit", remove the screw and green lock from the included SAE adapter fitting using a 5/64" Allen wrench. Next, assemble and torque the SAE adapter fitting to the PTFE hose's -6AN straight end.

Install the 90 deg hose end to the back of the fuel rail using the supplied -6AN fitting and a 11/16" wrench. Route the PTFE hose down the firewall towards the OEM fuel pressure regulator (FPR) underneath the vehicle. Lightly lubricate the FPR's mating male outlet with oil and then fully insert the included SAE fitting.

Line up the hole and place the green lock onto the SAE fitting. Secure the small screw (as shown) using the 5/64" Allen hex wrench.



18. After everything is reinstalled, cycle the keyed ignition switch ON/OFF a few times (without starting the engine). This allows the fuel pump to prime the fuel system.

CHECK FOR LEAKS! If none are found, start the engine and check for leaks while the engine is running.

