

WIRELESS STEERING WHEEL CONTROLS

USER GUIDE AND INSTRUCTIONS

JULY 2016



CONTENTS

INTRODUCTION	PAGE 1
SPECIFICATION	PAGE 2
TRANSMITTER	PAGE 4
RECEIVER	PAGE 5
RELAY CONTROL UNIT	PAGE 6
RELAY CONTROL UNIT - PIN OUT	PAGE 7
RESET	PAGE 8
RELAY FUNCTION CONFIGURATION	PAGE 9
CHANNEL POSITION CONFIGURATION	PAGE 10

CONTACT INFORMATION

CARTEK AUTOMOTIVE ELECTRONICS LTD

Unit 25, Mitchell Point
Ensign Way, Hamble
Southampton
SO31 4RF
UNITED KINGDOM

+44(0)2380 457747

info@cartekmotorsport.com

www.CARTEKMOTORSPORT.com

INTRODUCTION



INTRODUCTION

The **Wireless Steering Wheel Controls** from **CARTEK** offers a simple way to bring electrical functions to the driver's fingertips. The system consists of 4 main components:

- **Steering Wheel Pushbutton Panel (8 channels)**
- **Transmitter Module (mounted on pushbutton panel)**
- **Receiver**
- **Relay Control Unit (8 channels)**

The system has 8 pushbutton switches which are wirelessly linked to 8 relays within the Relay Control Unit. These relays are microprocessor controlled and individually configurable to provide a choice of functions including momentary, latching and flashing modes.

The wireless communication link is by infrared, not radio. This eliminates the problem of external radio interference and provides a reliable response time of 70mS which is quick enough for gear shifting control.

SPECIFICATION

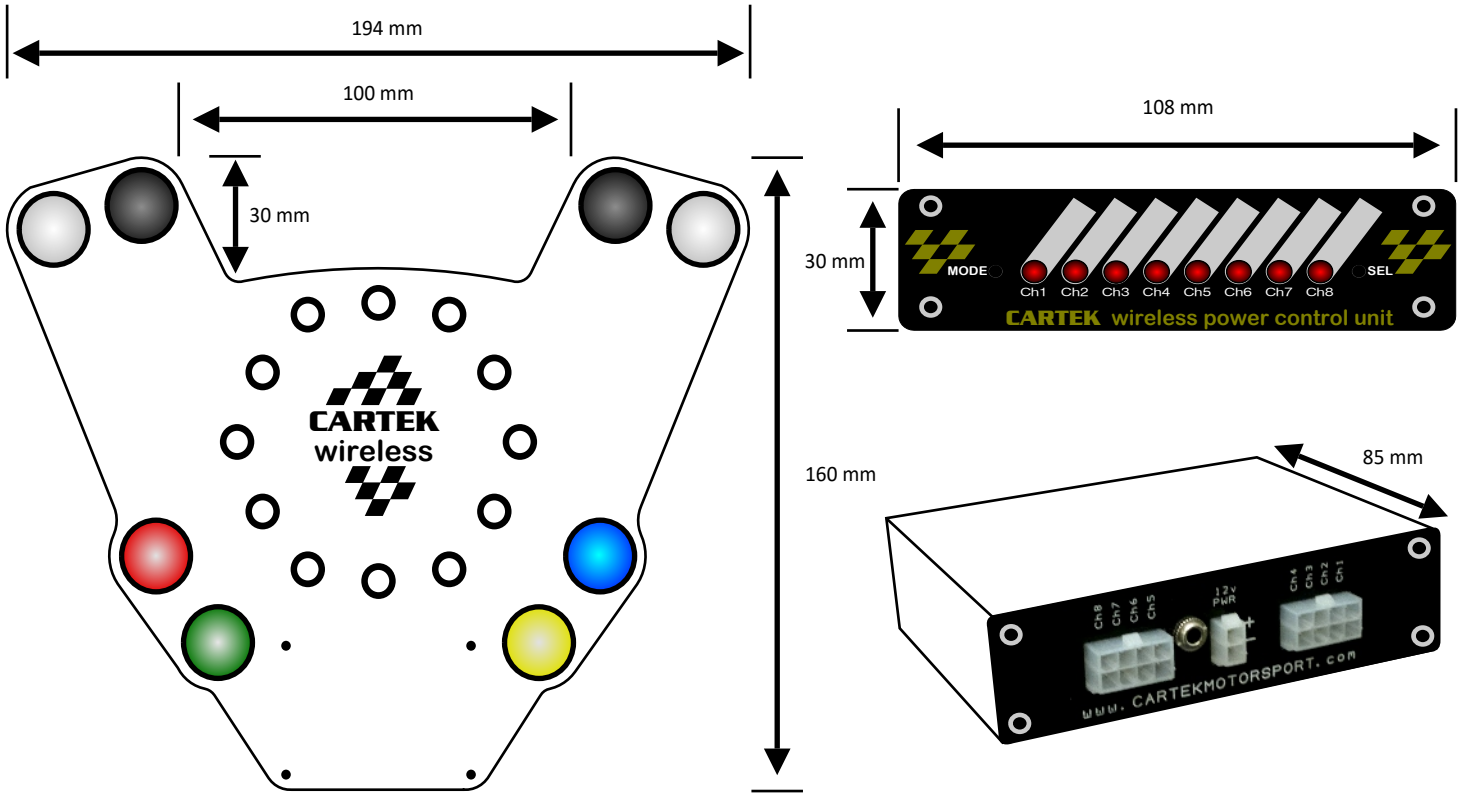

<u>RELAY CONTROL UNIT</u>	
SIZE:	W=108 mm, H=30 mm, L=85 mm
WEIGHT:	240g
REAR CONNECTORS:	2 x 8 Way MOLEX Minifit 1 x 2 Way MOLEX Minifit 1 x Jack Plug
POWER:	12V
RELAY CURRENT RATING:	10A
RESPONSE TIME:	70ms
<u>STEERING WHEEL SWITCH PANEL</u>	
SIZE:	W=194 mm, H=160 mm
WEIGHT:	220g (INC BATTERY)
PUSHBUTTON COLOURS:	BLACK, WHITE, RED, GREEN, BLUE, YELLOW
POWER:	INTERNAL BATTERY MN21 (LAST APPROX 3 YEARS)



WARNING

- Please read through the Instructions thoroughly before installing on to your race car.

**MOTORSPORT IS DANGEROUS.
THIS PRODUCT IS DESIGNED FOR MOTORSPORT USE ONLY AND SHOULD NOT
BE USED ON ROAD/STREET VEHICLES OR ON PUBLIC HIGHWAYS.
NO WARRANTY IS MADE OR IMPLIED REGARDING ANY CARTEK PRODUCTS TO
PROTECT USERS FROM INJURY OR DEATH.
USER ASSUMES ALL RISKS.**

TRANSMITTER

The infrared Transmitter module is mounted to rear of the Steering Wheel Pushbutton Panel and is battery powered. The Transmitter only consumes electrical power when a pushbutton is pressed and therefore does not need to be turned off when not in use.

When a pushbutton is pressed an LED on Transmitter will show the status of the internal battery. If the LED shows Green then the battery is in good condition, if the LED shows Red then the battery needs to be replaced.

To replace the battery remove the 4 small screws on the front of the pushbutton panel and remove the transmitter case. Carefully replace the battery with a new 12v MN21 type observing polarity. Replace the transmitter cover then check the battery status LED shows Green when any pushbutton is pressed.



TRANSMITTER

RECEIVER

The Receiver module should be mounted in a position to give an uninterrupted line-of-sight to the Transmitter module. The usual position is on the underside of the steering column.

When mounted correctly the driver should be able use their pushbutton functions through full 360° rotation of the steering wheel.

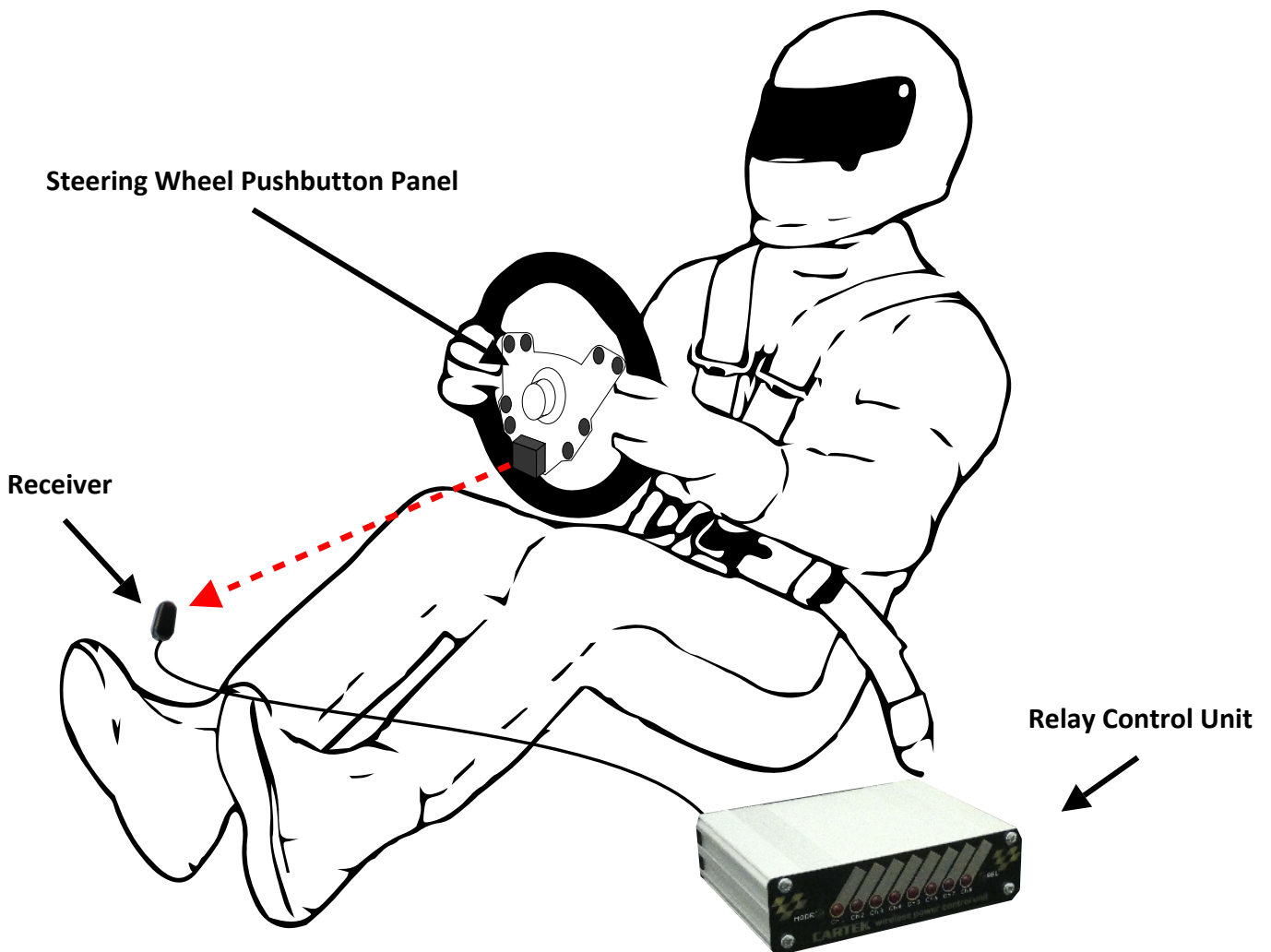

RELAY CONTROL UNIT

The Receiver is connected to the Relay Control Unit by a 3.5mm 'Jack' plug. This should be connected and disconnected only when power to the Relay Control Unit is OFF. Power is supplied to the Relay Control Unit via the 2 pin plug at the rear of the unit, care must be taken to observe the correct polarity.

Each of the 8 channels has an independent relay where the contacts are connected to corresponding connector pins on the rear of the unit. LEDs on the front of the unit will display the state of the corresponding relay, ON will indicate the relay contacts are closed, OFF will indicate open.

There are also two buttons on the front panel which are used to configure the individual relay functions.

NOTE: The Relay Control Unit is not sealed and should not be mounted in an area where it may come into contact with water or other liquids.

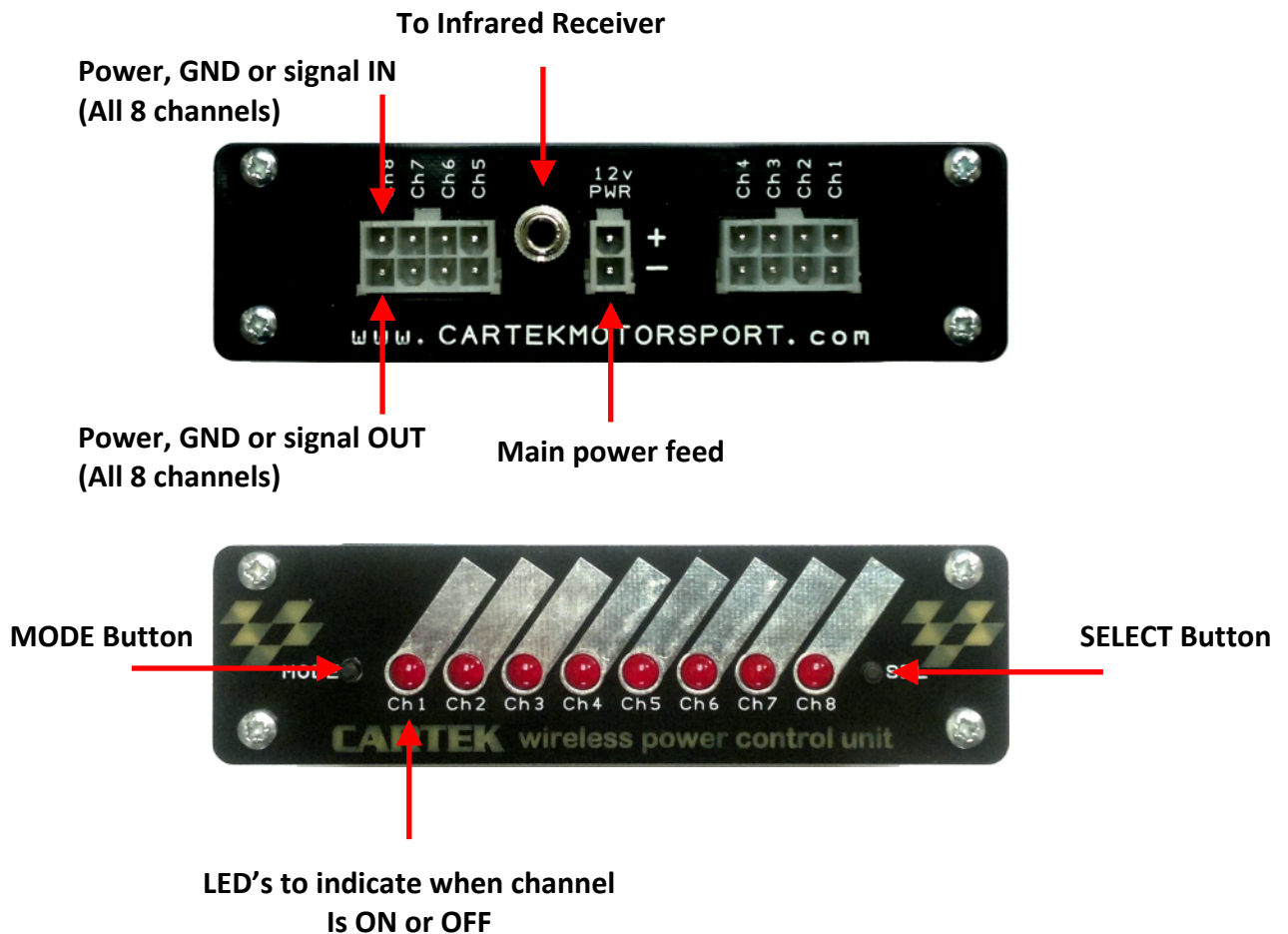

RELAY CONTROL UNIT - PIN OUT

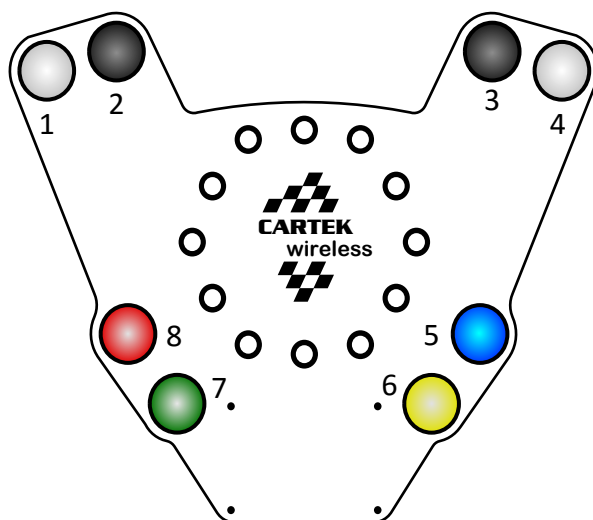

Connector 1

- Pin 1 - Channel 8 IN (Power, GND or signal)
- Pin 2 - Channel 8 OUT (Power, GND or signal)
- Pin 3 - Channel 7 IN (Power, GND or signal)
- Pin 4 - Channel 7 OUT (Power, GND or signal)
- Pin 5 - Channel 6 IN (Power, GND or signal)
- Pin 6 - Channel 6 OUT (Power, GND or signal)
- Pin 7 - Channel 5 IN (Power, GND or signal)
- Pin 8 - Channel 5 OUT (Power, GND or signal)

Connector 2

- Jack Plug - Infrared Sensor

Connector 3

- Pin 1 - 12V
- Pin 2 - GND

Connector 4

- Pin 1 - Channel 4 IN (Power, GND or signal)
- Pin 2 - Channel 4 OUT (Power, GND or signal)
- Pin 3 - Channel 3 IN (Power, GND or signal)
- Pin 4 - Channel 3 OUT (Power, GND or signal)
- Pin 5 - Channel 2 IN (Power, GND or signal)
- Pin 6 - Channel 2 OUT (Power, GND or signal)
- Pin 7 - Channel 1 IN (Power, GND or signal)
- Pin 8 - Channel 1 OUT (Power, GND or signal)

RESET

The Relay Control Unit can be fully reset back to factory default settings by pressing both buttons on the front panel whilst switching power ON. When all LEDs begin flashing then the buttons can be released.

A full reset will result in all relays being configured to momentary action (Function 1) with steering wheel pushbutton 1 being assigned to relay 1, pushbutton 2 to relay 2, etc.



①

Press and hold both buttons on the front panel with power disconnected



②

Whilst still holding both buttons connect power to the Relay Unit



RELAY FUNCTION CONFIGURATION

Each relay can be individually configured to perform any 1 of 6 different functions:

Function 1: Momentary action

Function 2: Latching (no memory)

Function 3: Latching (with power-off memory)

Function 4: Flashing (slow speed, minimum 5 flashes)

Function 5: Flashing (fast speed, minimum 3 flashes)

Function 6: Flashing (slow speed, Latching)

To begin the **Function** selection procedure:

- Press and hold the **MODE** button while switching the power to the Relay Control Unit ON then release the button. Channel 1 LED will now begin to flash to indicate which function is currently allocated to Relay 1, i.e. 1 flash then pause means Function 1, 2 flashes means Function 2 etc.

To change the **Function**:

- Press the **SEL** button. Each time the SEL button is pressed the Function number for that relay will increment.
- When the required function has been selected then press the **MODE** button again and the next relay can be configured. Each time a relay function is changed it is automatically stored into memory.
- The mode configuration procedure can be ended at any time by switching the power OFF.



CHANNEL POSITION CONFIGURATION

After a full reset, Steering Wheel Pushbutton 1 will be assigned to Relay 1, Pushbutton 2 will be assigned to Relay 2 etc. However, if a driver decides that they would prefer the position of a function to be changed on the steering wheel panel, e.g. left to right, then this can be done without the need for any rewiring.

To alter which pushbutton is allocated to which relay:

- Press and hold the **SEL** button while switching the Relay Control Unit ON then release the button. Channel 1 LED will now begin to flash.
- Whilst this LED is flashing press the Steering Wheel Pushbutton that is to be allocated to Relay 1. On pressing the preferred Pushbutton, Channel 1 LED will stop flashing and Channel 2 LED will now begin to flash and can be allocated.
- Continue this procedure until all 8 relay channels have been allocated to a pushbutton.

NOTE - When following the channel position configuration, each of the 8 relays must each be allocated to one pushbutton.